

# 74HC164; 74HCT164

## 8-bit serial-in, parallel-out shift register

Rev. 04 — 2 February 2010

Product data sheet

### 1. General description

---

The 74HC164; 74HCT164 are high-speed Si-gate CMOS devices and are pin compatible with Low power Schottky TTL (LSTTL). They are specified in compliance with JEDEC standard no. 7A.

The 74HC164; 74HCT164 are 8-bit edge-triggered shift registers with serial data entry and an output from each of the eight stages. Data is entered serially through one of two inputs (DSA or DSB); either input can be used as an active HIGH enable for data entry through the other input. Both inputs must be connected together or an unused input must be tied HIGH.

Data shifts one place to the right on each LOW-to-HIGH transition of the clock (CP) input and enters into Q0, which is the logical AND of the two data inputs (DSA and DSB) that existed one set-up time prior to the rising clock edge.

A LOW level on the master reset ( $\overline{\text{MR}}$ ) input overrides all other inputs and clears the register asynchronously, forcing all outputs LOW.

### 2. Features

---

- Input levels:
  - ◆ For 74HC164: CMOS level
  - ◆ For 74HCT164: TTL level
- Gated serial data inputs
- Asynchronous master reset
- Complies with JEDEC standard no. 7A
- ESD protection:
  - ◆ HBM JESD22-A114F exceeds 2000 V
  - ◆ MM JESD22-A115-A exceeds 200 V.
- Multiple package options
- Specified from  $-40\text{ }^{\circ}\text{C}$  to  $+85\text{ }^{\circ}\text{C}$  and  $-40\text{ }^{\circ}\text{C}$  to  $+125\text{ }^{\circ}\text{C}$ .

### 3. Ordering information

Table 1. Ordering information

Type number	Package			Version
	Temperature range	Name	Description	
74HC164N 74HCT164N	-40 °C to +125 °C	DIP14	plastic dual in-line package; 14 leads (300 mil)	SOT27-1
74HC164D 74HCT164D	-40 °C to +125 °C	SO14	plastic small outline package; 14 leads; body width 3.9 mm	SOT108-1
74HC164DB 74HCT164DB	-40 °C to +125 °C	SSOP14	plastic shrink small outline package; 14 leads; body width 5.3 mm	SOT337-1
74HC164PW 74HCT164PW	-40 °C to +125 °C	TSSOP14	plastic thin shrink small outline package; 14 leads; body width 4.4 mm	SOT402-1
74HC164BQ 74HCT164BQ	-40 °C to +125 °C	DHVQFN14	plastic dual in-line compatible thermal enhanced very thin quad flat package; no leads; 14 terminals; body 2.5 × 3 × 0.85 mm	SOT762-1

### 4. Functional diagram

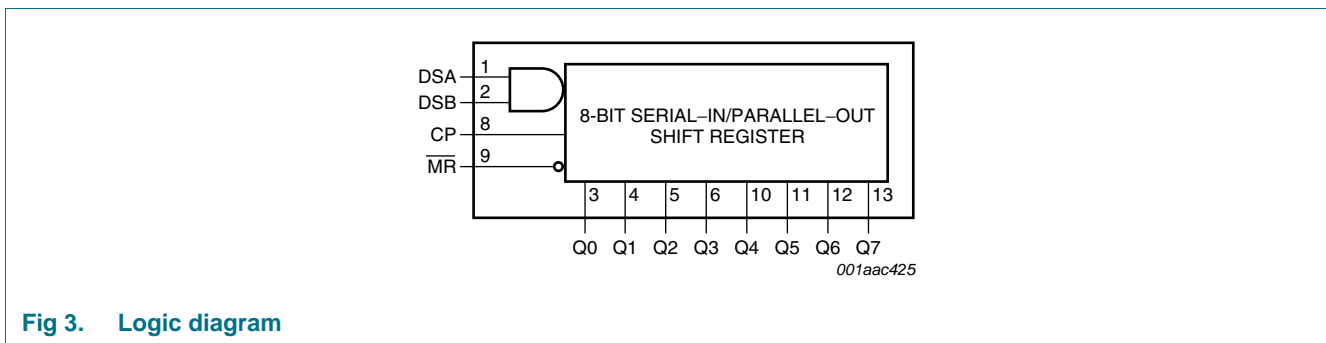
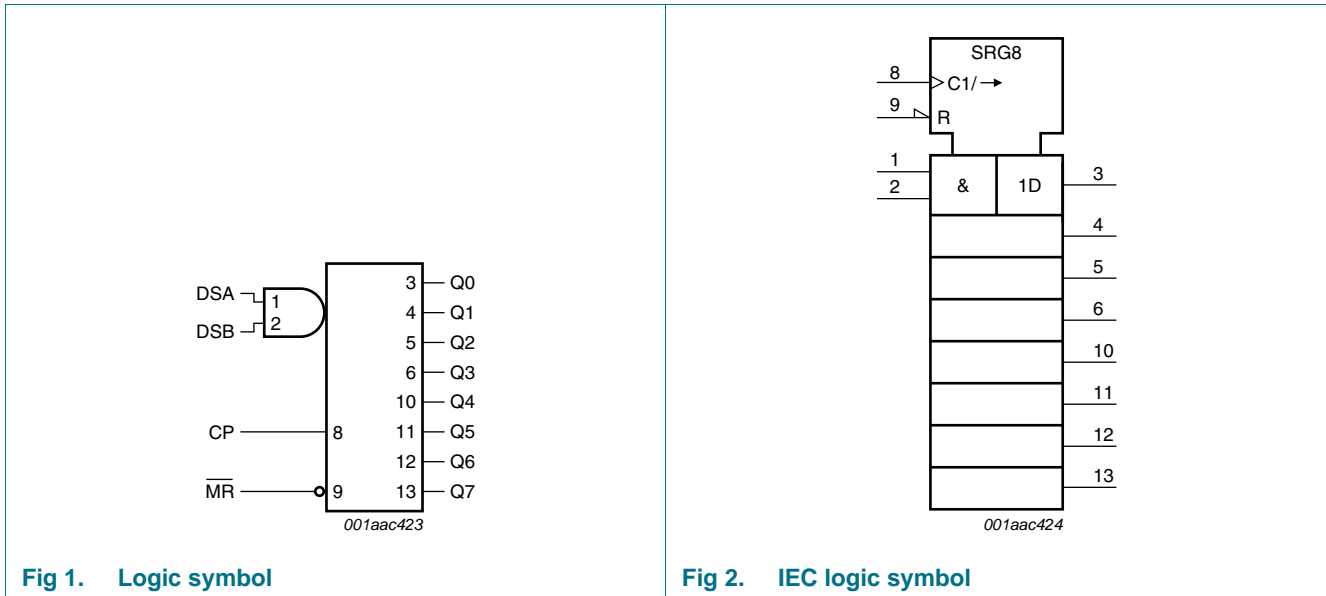

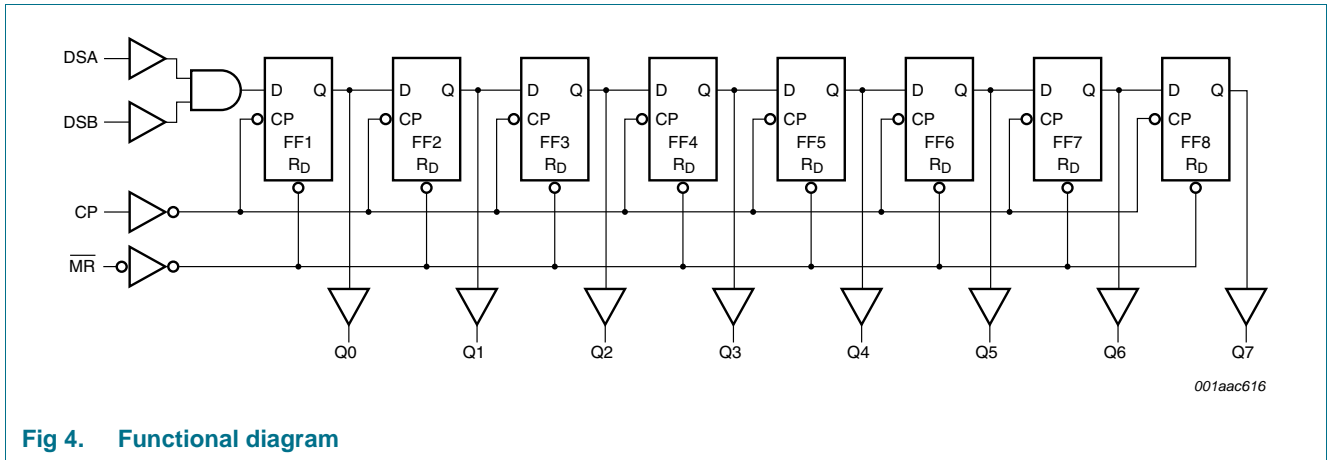

Fig 4. Functional diagram

## 5. Pinning information

### 5.1 Pinning

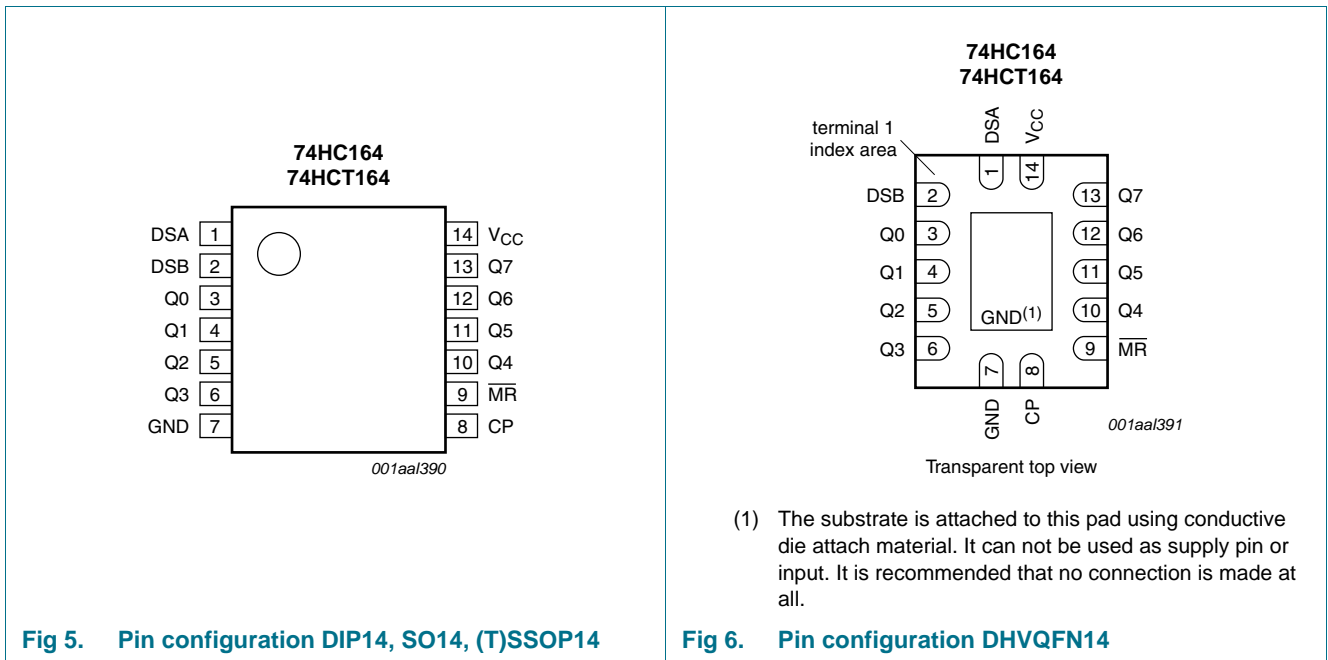

Fig 5. Pin configuration DIP14, SO14, (T)SSOP14

Fig 6. Pin configuration DHVQFN14

## 5.2 Pin description

**Table 2. Pin description**

Symbol	Pin	Description
DSA	1	data input
DSB	2	data input
Q0 to Q7	3, 4, 5, 6, 10, 11, 12, 13	output
GND	7	ground (0 V)
CP	8	clock input (LOW-to-HIGH, edge-triggered)
$\overline{\text{MR}}$	9	master reset input (active LOW)
V <sub>CC</sub>	14	positive supply voltage

## 6. Functional description

**Table 3. Function table<sup>[1]</sup>**

Operating modes	Input				Output	
	$\overline{\text{MR}}$	CP	DSA	DSB	Q0	Q1 to Q7
Reset (clear)	L	X	X	X	L	L to L
Shift	H	↑	l	l	L	q0 to q6
	H	↑	l	h	L	q0 to q6
	H	↑	h	l	L	q0 to q6
	H	↑	h	h	H	q0 to q6

- [1] H = HIGH voltage level  
 h = HIGH voltage level one set-up time prior to the LOW-to-HIGH clock transition  
 L = LOW voltage level  
 l = LOW voltage level one set-up time prior to the LOW-to-HIGH clock transition  
 q = lower case letters indicate the state of the referenced input one set-up time prior to the LOW-to-HIGH clock transition  
 ↑ = LOW-to-HIGH clock transition

## 7. Limiting values

**Table 4. Limiting values**

In accordance with the Absolute Maximum Rating System (IEC 60134). Voltages are referenced to GND (ground = 0 V).

Symbol	Parameter	Conditions	Min	Max	Unit
V <sub>CC</sub>	supply voltage		-0.5	+7	V
I <sub>IK</sub>	input clamping current	V <sub>I</sub> < -0.5 V or V <sub>I</sub> > V <sub>CC</sub> + 0.5 V	[1] -	±20	mA
I <sub>OK</sub>	output clamping current	V <sub>O</sub> < -0.5 V or V <sub>O</sub> > V <sub>CC</sub> + 0.5 V	[1] -	±20	mA
I <sub>O</sub>	output current	-0.5 V < V <sub>O</sub> < V <sub>CC</sub> + 0.5 V	-	±25	mA
I <sub>CC</sub>	supply current		-	50	mA
I <sub>GND</sub>	ground current		-50	-	mA
T <sub>stg</sub>	storage temperature		-65	+150	°C

**Table 4. Limiting values ...continued**

In accordance with the Absolute Maximum Rating System (IEC 60134). Voltages are referenced to GND (ground = 0 V).

Symbol	Parameter	Conditions	Min	Max	Unit
P <sub>tot</sub>	total power dissipation		[2]		
	DIP14 package		-	750	mW
	SO14, (T)SSOP14 and DHVQFN14 packages		-	500	mW

[1] The input and output voltage ratings may be exceeded if the input and output current ratings are observed.

- [2] For DIP14 package: P<sub>tot</sub> derates linearly with 12 mW/K above 70 °C.  
 For SO14 package: P<sub>tot</sub> derates linearly with 8 mW/K above 70 °C.  
 For (T)SSOP14 packages: P<sub>tot</sub> derates linearly with 5.5 mW/K above 60 °C.  
 For DHVQFN14 packages: P<sub>tot</sub> derates linearly with 4.5 mW/K above 60 °C.

## 8. Recommended operating conditions

**Table 5. Recommended operating conditions**

Voltages are referenced to GND (ground = 0 V)

Symbol	Parameter	Conditions	74HC164			74HCT164			Unit
			Min	Typ	Max	Min	Typ	Max	
V <sub>CC</sub>	supply voltage		2.0	5.0	6.0	4.5	5.0	5.5	V
V <sub>I</sub>	input voltage		0	-	V <sub>CC</sub>	0	-	V <sub>CC</sub>	V
V <sub>O</sub>	output voltage		0	-	V <sub>CC</sub>	0	-	V <sub>CC</sub>	V
T <sub>amb</sub>	ambient temperature		-40	+25	+125	-40	+25	+125	°C
Δt/ΔV	input transition rise and fall rate	V <sub>CC</sub> = 2.0 V	-	-	625	-	-	-	ns/V
		V <sub>CC</sub> = 4.5 V	-	1.67	139	-	1.67	139	ns/V
		V <sub>CC</sub> = 6.0 V	-	-	83	-	-	-	ns/V

## 9. Static characteristics

**Table 6. Static characteristics**

At recommended operating conditions; voltages are referenced to GND (ground = 0 V).

Symbol	Parameter	Conditions	25 °C			-40 °C to +85 °C		-40 °C to +125 °C		Unit
			Min	Typ	Max	Min	Max	Min	Max	
<b>74HC164</b>										
V <sub>IH</sub>	HIGH-level input voltage	V <sub>CC</sub> = 2.0 V	1.5	1.2	-	1.5	-	1.5	-	V
		V <sub>CC</sub> = 4.5 V	3.15	2.4	-	3.15	-	3.15	-	V
		V <sub>CC</sub> = 6.0 V	4.2	3.2	-	4.2	-	4.2	-	V
V <sub>IL</sub>	LOW-level input voltage	V <sub>CC</sub> = 2.0 V	-	0.8	0.5	-	0.5	-	0.5	V
		V <sub>CC</sub> = 4.5 V	-	2.1	1.35	-	1.35	-	1.35	V
		V <sub>CC</sub> = 6.0 V	-	2.8	1.8	-	1.8	-	1.8	V

**Table 6. Static characteristics ...continued**

At recommended operating conditions; voltages are referenced to GND (ground = 0 V).

Symbol	Parameter	Conditions	25 °C			-40 °C to +85 °C		-40 °C to +125 °C		Unit
			Min	Typ	Max	Min	Max	Min	Max	
V <sub>OH</sub>	HIGH-level output voltage	V <sub>I</sub> = V <sub>IH</sub> or V <sub>IL</sub>								
		I <sub>O</sub> = -20 μA; V <sub>CC</sub> = 2.0 V	1.9	2.0	-	1.9	-	1.9	-	V
		I <sub>O</sub> = -20 μA; V <sub>CC</sub> = 4.5 V	4.4	4.5	-	4.4	-	4.4	-	V
		I <sub>O</sub> = -20 μA; V <sub>CC</sub> = 6.0 V	5.9	6.0	-	5.9	-	5.9	-	V
		I <sub>O</sub> = -4.0 mA; V <sub>CC</sub> = 4.5 V	3.98	4.32	-	3.84	-	3.7	-	V
		I <sub>O</sub> = -5.2 mA; V <sub>CC</sub> = 6.0 V	5.48	5.81	-	5.34	-	5.2	-	V
V <sub>OL</sub>	LOW-level output voltage	V <sub>I</sub> = V <sub>IH</sub> or V <sub>IL</sub>								
		I <sub>O</sub> = 20 μA; V <sub>CC</sub> = 2.0 V	-	0	0.1	-	0.1	-	0.1	V
		I <sub>O</sub> = 20 μA; V <sub>CC</sub> = 4.5 V	-	0	0.1	-	0.1	-	0.1	V
		I <sub>O</sub> = 20 μA; V <sub>CC</sub> = 6.0 V	-	0	0.1	-	0.1	-	0.1	V
		I <sub>O</sub> = 4.0 mA; V <sub>CC</sub> = 4.5 V	-	0.15	0.26	-	0.33	-	0.4	V
		I <sub>O</sub> = 5.2 mA; V <sub>CC</sub> = 6.0 V	-	0.16	0.26	-	0.33	-	0.4	V
I <sub>I</sub>	input leakage current	V <sub>I</sub> = V <sub>CC</sub> or GND; V <sub>CC</sub> = 6.0 V	-	-	±0.1	-	±1	-	±1	μA
I <sub>CC</sub>	supply current	V <sub>I</sub> = V <sub>CC</sub> or GND; I <sub>O</sub> = 0 A; V <sub>CC</sub> = 6.0 V	-	-	8.0	-	80	-	160	μA
C <sub>I</sub>	input capacitance		-	3.5	-	-	-	-	-	pF
<b>74HCT164</b>										
V <sub>IH</sub>	HIGH-level input voltage	V <sub>CC</sub> = 4.5 V to 5.5 V	2.0	1.6	-	2.0	-	2.0	-	V
V <sub>IL</sub>	LOW-level input voltage	V <sub>CC</sub> = 4.5 V to 5.5 V	-	1.2	0.8	-	0.8	-	0.8	V
V <sub>OH</sub>	HIGH-level output voltage	V <sub>I</sub> = V <sub>IH</sub> or V <sub>IL</sub> ; V <sub>CC</sub> = 4.5 V								
		I <sub>O</sub> = -20 μA	4.4	4.5	-	4.4	-	4.4	-	V
		I <sub>O</sub> = -4.0 mA	3.98	4.32	-	3.84	-	3.7	-	V
V <sub>OL</sub>	LOW-level output voltage	V <sub>I</sub> = V <sub>IH</sub> or V <sub>IL</sub> ; V <sub>CC</sub> = 4.5 V								
		I <sub>O</sub> = 20 μA; V <sub>CC</sub> = 4.5 V	-	0	0.1	-	0.1	-	0.1	V
		I <sub>O</sub> = 5.2 mA; V <sub>CC</sub> = 6.0 V	-	0.15	0.26	-	0.33	-	0.4	V
I <sub>I</sub>	input leakage current	V <sub>I</sub> = V <sub>CC</sub> or GND; V <sub>CC</sub> = 6.0 V	-	-	±0.1	-	±1	-	±1	μA
I <sub>CC</sub>	supply current	V <sub>I</sub> = V <sub>CC</sub> or GND; I <sub>O</sub> = 0 A; V <sub>CC</sub> = 6.0 V	-	-	8	-	80	-	160	μA
ΔI <sub>CC</sub>	additional supply current	per input pin; V <sub>I</sub> = V <sub>CC</sub> - 2.1 V; I <sub>O</sub> = 0 A; other inputs at V <sub>CC</sub> or GND; V <sub>CC</sub> = 4.5 V to 5.5 V	-	100	360	-	450	-	490	μA
C <sub>I</sub>	input capacitance		-	3.5	-	-	-	-	-	pF

## 10. Dynamic characteristics

**Table 7. Dynamic characteristics**

$GND = 0\text{ V}$ ;  $t_r = t_f = 6\text{ ns}$ ;  $C_L = 50\text{ pF}$ ; test circuit see [Figure 10](#); unless otherwise specified

Symbol	Parameter	Conditions	25 °C			-40 °C to +85 °C		-40 °C to +125 °C		Unit
			Min	Typ	Max	Min	Max	Min	Max	
<b>74HC164</b>										
$t_{pd}$	propagation delay	CP to Qn; see <a href="#">Figure 7</a> <sup>[1]</sup>								
		$V_{CC} = 2.0\text{ V}$	-	41	170	-	215	-	255	ns
		$V_{CC} = 4.5\text{ V}$	-	15	34	-	43	-	51	ns
		$V_{CC} = 5.0\text{ V}$ ; $C_L = 15\text{ pF}$	-	12	-	-	-	-	-	ns
		$V_{CC} = 6.0\text{ V}$	-	12	29	-	37	-	43	ns
$t_{PHL}$	HIGH to LOW propagation delay	MR to Qn; see <a href="#">Figure 8</a>								
		$V_{CC} = 2.0\text{ V}$	-	39	140	-	175	-	210	ns
		$V_{CC} = 4.5\text{ V}$	-	14	28	-	35	-	42	ns
		$V_{CC} = 5.0\text{ V}$ ; $C_L = 15\text{ pF}$	-	11	-	-	-	-	-	ns
		$V_{CC} = 6.0\text{ V}$	-	11	24	-	30	-	36	ns
$t_t$	transition time	see <a href="#">Figure 7</a> <sup>[2]</sup>								
		$V_{CC} = 2.0\text{ V}$	-	19	75	-	95	-	110	ns
		$V_{CC} = 4.5\text{ V}$	-	7	15	-	19	-	22	ns
		$V_{CC} = 6.0\text{ V}$	-	6	13	-	16	-	19	ns
$t_{pw}$	pulse width	CP HIGH or LOW; see <a href="#">Figure 7</a>								
		$V_{CC} = 2.0\text{ V}$	80	14	-	100	-	120	-	ns
		$V_{CC} = 4.5\text{ V}$	16	5	-	20	-	24	-	ns
		$V_{CC} = 6.0\text{ V}$	14	4	-	17	-	20	-	ns
		MR LOW; see <a href="#">Figure 8</a>								
		$V_{CC} = 2.0\text{ V}$	60	17	-	75	-	90	-	ns
		$V_{CC} = 4.5\text{ V}$	12	6	-	15	-	18	-	ns
		$V_{CC} = 6.0\text{ V}$	10	5	-	13	-	15	-	ns
$t_{rec}$	recovery time	MR to CP; see <a href="#">Figure 8</a>								
		$V_{CC} = 2.0\text{ V}$	60	17	-	75	-	90	-	ns
		$V_{CC} = 4.5\text{ V}$	12	6	-	15	-	18	-	ns
		$V_{CC} = 6.0\text{ V}$	10	5	-	13	-	15	-	ns
$t_{su}$	set-up time	DSA, and DSB to CP; see <a href="#">Figure 9</a>								
		$V_{CC} = 2.0\text{ V}$	60	8	-	75	-	90	-	ns
		$V_{CC} = 4.5\text{ V}$	12	3	-	15	-	18	-	ns
		$V_{CC} = 6.0\text{ V}$	10	2	-	13	-	15	-	ns
$t_h$	hold time	DSA, and DSB to CP; see <a href="#">Figure 9</a>								
		$V_{CC} = 2.0\text{ V}$	+4	-6	-	4	-	4	-	ns
		$V_{CC} = 4.5\text{ V}$	+4	-2	-	4	-	4	-	ns
		$V_{CC} = 6.0\text{ V}$	+4	-2	-	4	-	4	-	ns

**Table 7. Dynamic characteristics**

$GND = 0\text{ V}$ ;  $t_r = t_f = 6\text{ ns}$ ;  $C_L = 50\text{ pF}$ ; test circuit see [Figure 10](#); unless otherwise specified

Symbol	Parameter	Conditions	25 °C			−40 °C to +85 °C		−40 °C to +125 °C		Unit
			Min	Typ	Max	Min	Max	Min	Max	
$f_{max}$	maximum frequency	for $C_p$ , see <a href="#">Figure 7</a>								
		$V_{CC} = 2.0\text{ V}$	6	23	-	5	-	4	-	MHz
		$V_{CC} = 4.5\text{ V}$	30	71	-	24	-	20	-	MHz
		$V_{CC} = 5.0\text{ V}$ ; $C_L = 15\text{ pF}$	-	78	-	-	-	-	-	MHz
		$V_{CC} = 6.0\text{ V}$	35	85	-	28	-	24	-	MHz
$C_{PD}$	power dissipation capacitance	per package; $V_I = GND$ to $V_{CC}$ <a href="#">[3]</a>	-	40	-	-	-	-	-	pF
<b>74HCT164</b>										
$t_{pd}$	propagation delay	CP to $Q_n$ ; see <a href="#">Figure 7</a> <a href="#">[1]</a>								
		$V_{CC} = 4.5\text{ V}$	-	17	36	-	45	-	54	ns
		$V_{CC} = 5.0\text{ V}$ ; $C_L = 15\text{ pF}$	-	14	-	-	-	-	-	ns
$t_{PHL}$	HIGH to LOW propagation delay	$\overline{MR}$ to $Q_n$ ; see <a href="#">Figure 8</a>								
		$V_{CC} = 4.5\text{ V}$	-	19	38	-	48	-	57	ns
		$V_{CC} = 5.0\text{ V}$ ; $C_L = 15\text{ pF}$	-	16	-	-	-	-	-	ns
$t_t$	transition time	see <a href="#">Figure 7</a> <a href="#">[2]</a>								
		$V_{CC} = 4.5\text{ V}$	-	7	15	-	19	-	22	ns
$t_W$	pulse width	CP HIGH or LOW; see <a href="#">Figure 7</a>								
		$V_{CC} = 4.5\text{ V}$	18	7	-	23	-	27	-	ns
		$\overline{MR}$ LOW; see <a href="#">Figure 8</a>								
		$V_{CC} = 4.5\text{ V}$	18	10	-	23	-	27	-	ns
$t_{rec}$	recovery time	$\overline{MR}$ to CP; see <a href="#">Figure 8</a>								
		$V_{CC} = 4.5\text{ V}$	16	7	-	20	-	24	-	ns
$t_{su}$	set-up time	DSA, and DSB to CP; see <a href="#">Figure 9</a>								
		$V_{CC} = 4.5\text{ V}$	12	6	-	15	-	18	-	ns
$t_h$	hold time	DSA, and DSB to CP; see <a href="#">Figure 9</a>								
		$V_{CC} = 4.5\text{ V}$	+4	-2	-	4	-	4	-	ns
$f_{max}$	maximum frequency	for $C_p$ , see <a href="#">Figure 7</a>								
		$V_{CC} = 4.5\text{ V}$	27	55	-	22	-	18	-	MHz
		$V_{CC} = 5.0\text{ V}$ ; $C_L = 15\text{ pF}$	-	61	-	-	-	-	-	MHz

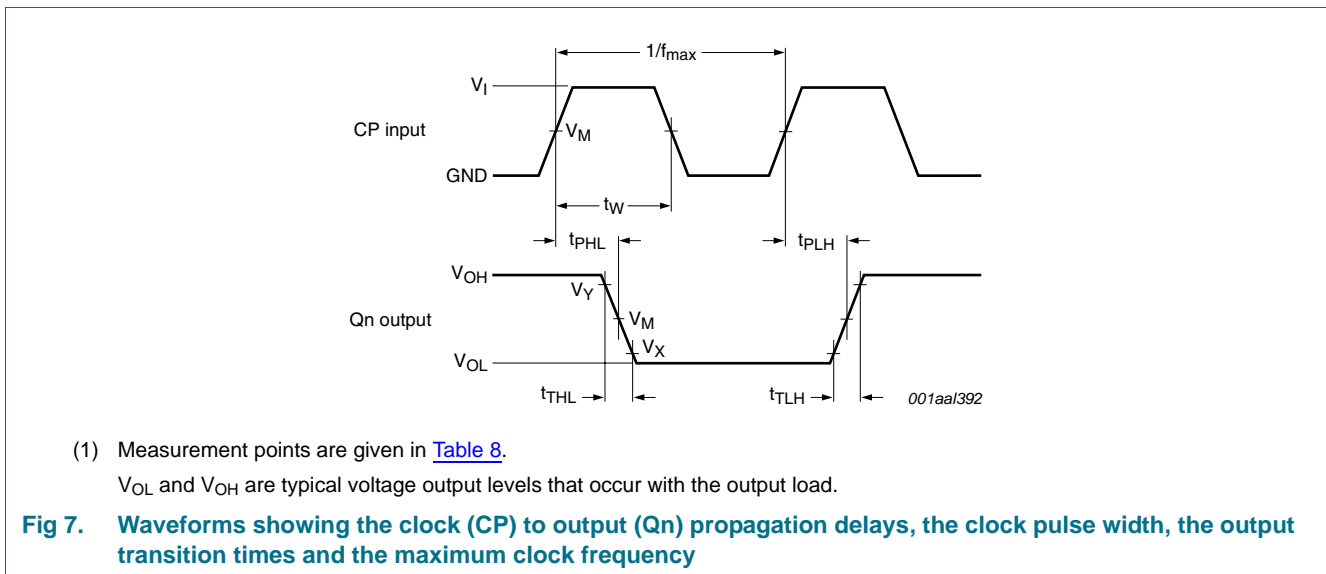

**Table 7. Dynamic characteristics**

$GND = 0\text{ V}$ ;  $t_r = t_f = 6\text{ ns}$ ;  $C_L = 50\text{ pF}$ ; test circuit see [Figure 10](#); unless otherwise specified

Symbol	Parameter	Conditions	25 °C			-40 °C to +85 °C		-40 °C to +125 °C		Unit
			Min	Typ	Max	Min	Max	Min	Max	
$C_{PD}$	power dissipation capacitance	per package; $V_I = GND\text{ to }V_{CC} - 1.5\text{ V}$	-	40	-	-	-	-	-	pF

- [1]  $t_{pd}$  is the same as  $t_{PHL}$  and  $t_{PLH}$ .
- [2]  $t_t$  is the same as  $t_{THL}$  and  $t_{TLH}$ .
- [3]  $C_{PD}$  is used to determine the dynamic power dissipation ( $P_D$  in  $\mu\text{W}$ ):  
 $P_D = C_{PD} \times V_{CC}^2 \times f_i \times N + \sum (C_L \times V_{CC}^2 \times f_o)$  where:  
 $f_i$  = input frequency in MHz;  
 $f_o$  = output frequency in MHz;  
 $C_L$  = output load capacitance in pF;  
 $V_{CC}$  = supply voltage in V;  
 $N$  = number of inputs switching;  
 $\sum (C_L \times V_{CC}^2 \times f_o)$  = sum of outputs.



**Table 8. Measurement points**

Type	Input		Output		
	$V_M$	$V_M$	$V_X$	$V_Y$	
74HC164	$0.5V_{CC}$	$0.5V_{CC}$	$0.1V_{CC}$	$0.9V_{CC}$	
74HCT164	1.3 V	1.3 V	$0.1V_{CC}$	$0.9V_{CC}$	

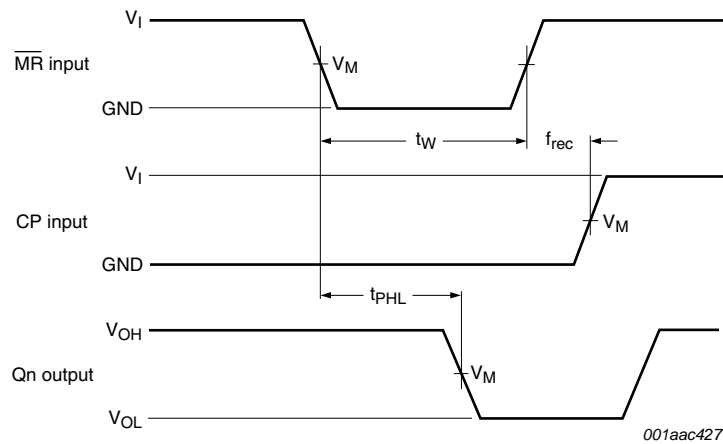

- (1) Measurement points are given in [Table 8](#).  
 $V_{OL}$  and  $V_{OH}$  are typical voltage output levels that occur with the output load.

**Fig 8. Waveforms showing the master reset ( $\overline{MR}$ ) pulse width, the master reset to output ( $Q_n$ ) propagation delays and the master reset to clock ( $CP$ ) removal time**

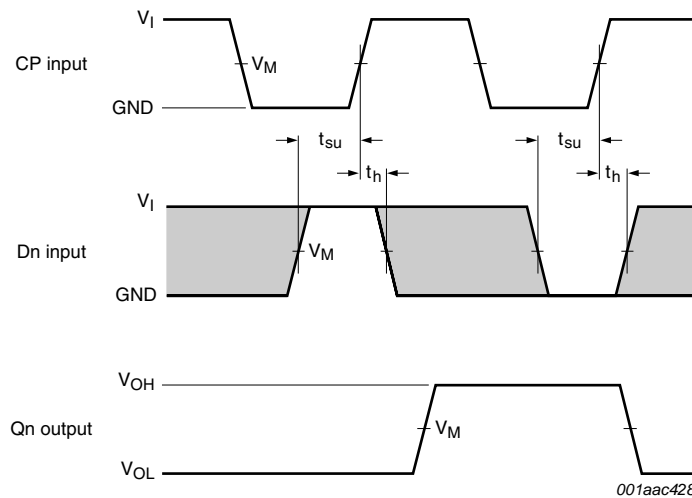

- (1) Measurement points are given in [Table 8](#).  
 $V_{OL}$  and  $V_{OH}$  are typical voltage output levels that occur with the output load.  
 The shaded areas indicate when the input is permitted to change for predictable output performance.

**Fig 9. Waveforms showing the data set-up and hold times for  $D_n$  inputs**

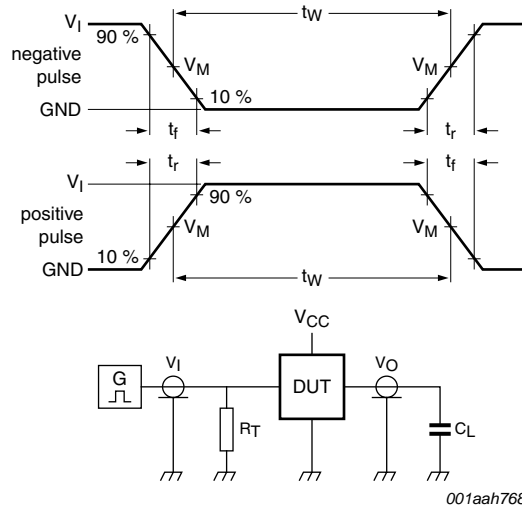

001aah768

Test data is given in [Table 9](#).

Definitions test circuit:

$R_T$  = termination resistance should be equal to output impedance  $Z_o$  of the pulse generator.

$C_L$  = load capacitance including jig and probe capacitance.

**Fig 10. Test circuit for measuring switching times**

**Table 9. Test data**

Type	Input		Load	Test
	$V_I$	$t_r, t_f$	$C_L$	
74HC164	$V_{CC}$	6.0 ns	15 pF, 50 pF	$t_{PLH}, t_{PHL}$
74HCT164	3.0 V	6.0 ns	15 pF, 50 pF	$t_{PLH}, t_{PHL}$

**11. Package outline**

DIP14: plastic dual in-line package; 14 leads (300 mil)

SOT27-1

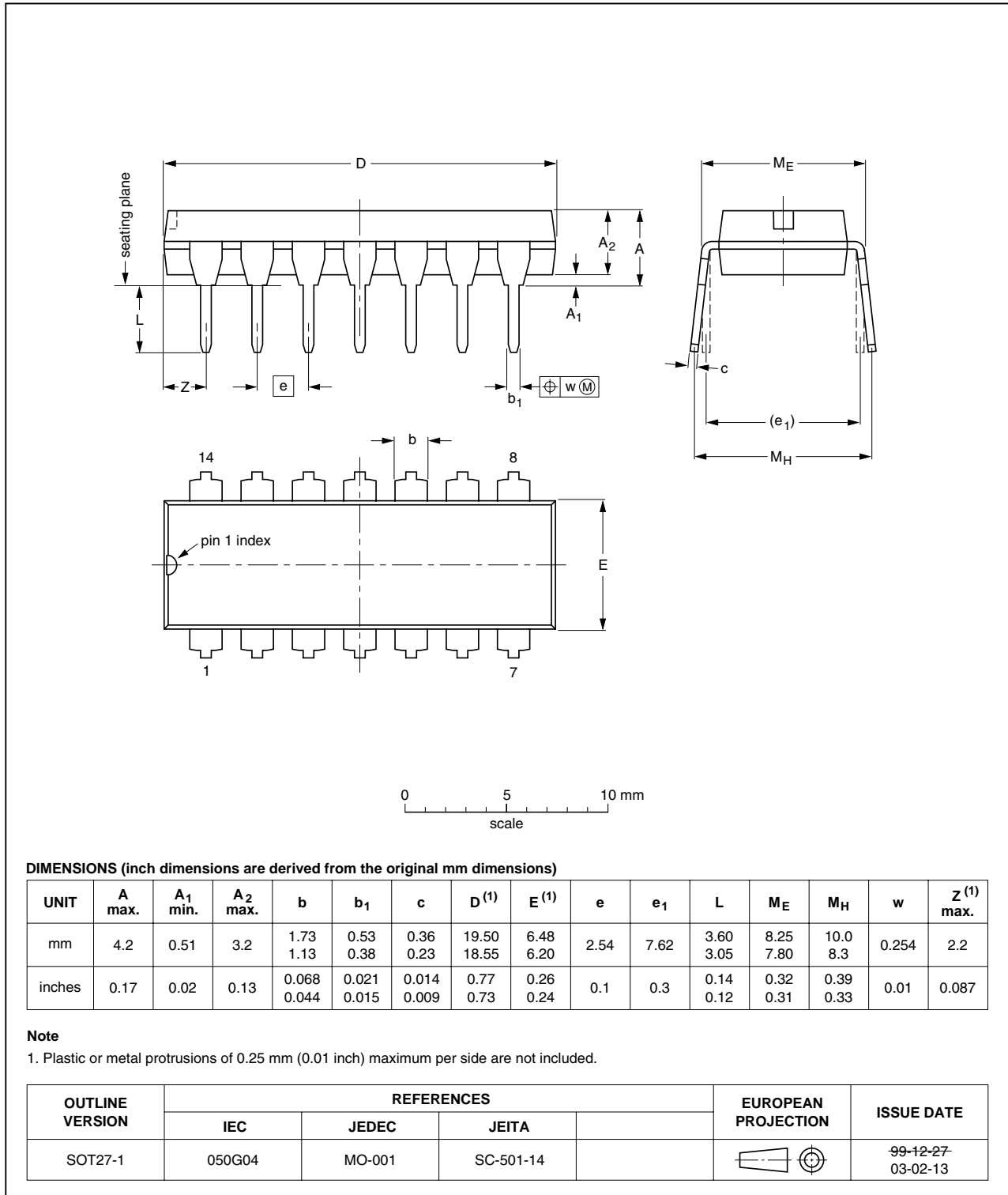

Fig 11. Package outline SOT27-1 (DIP14)

SO14: plastic small outline package; 14 leads; body width 3.9 mm

SOT108-1

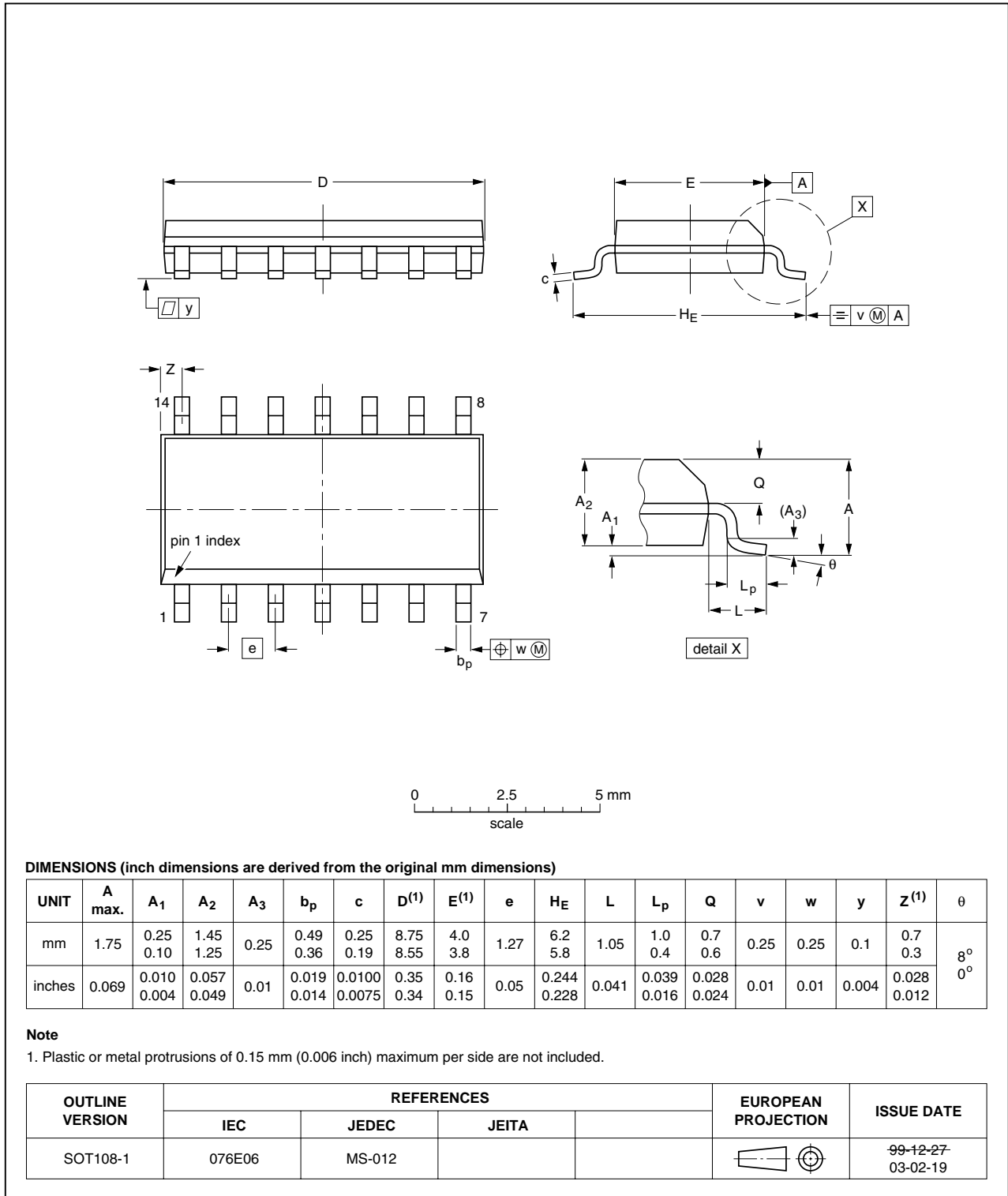

Fig 12. Package outline SOT108-1 (SO14)

SSOP14: plastic shrink small outline package; 14 leads; body width 5.3 mm

SOT337-1

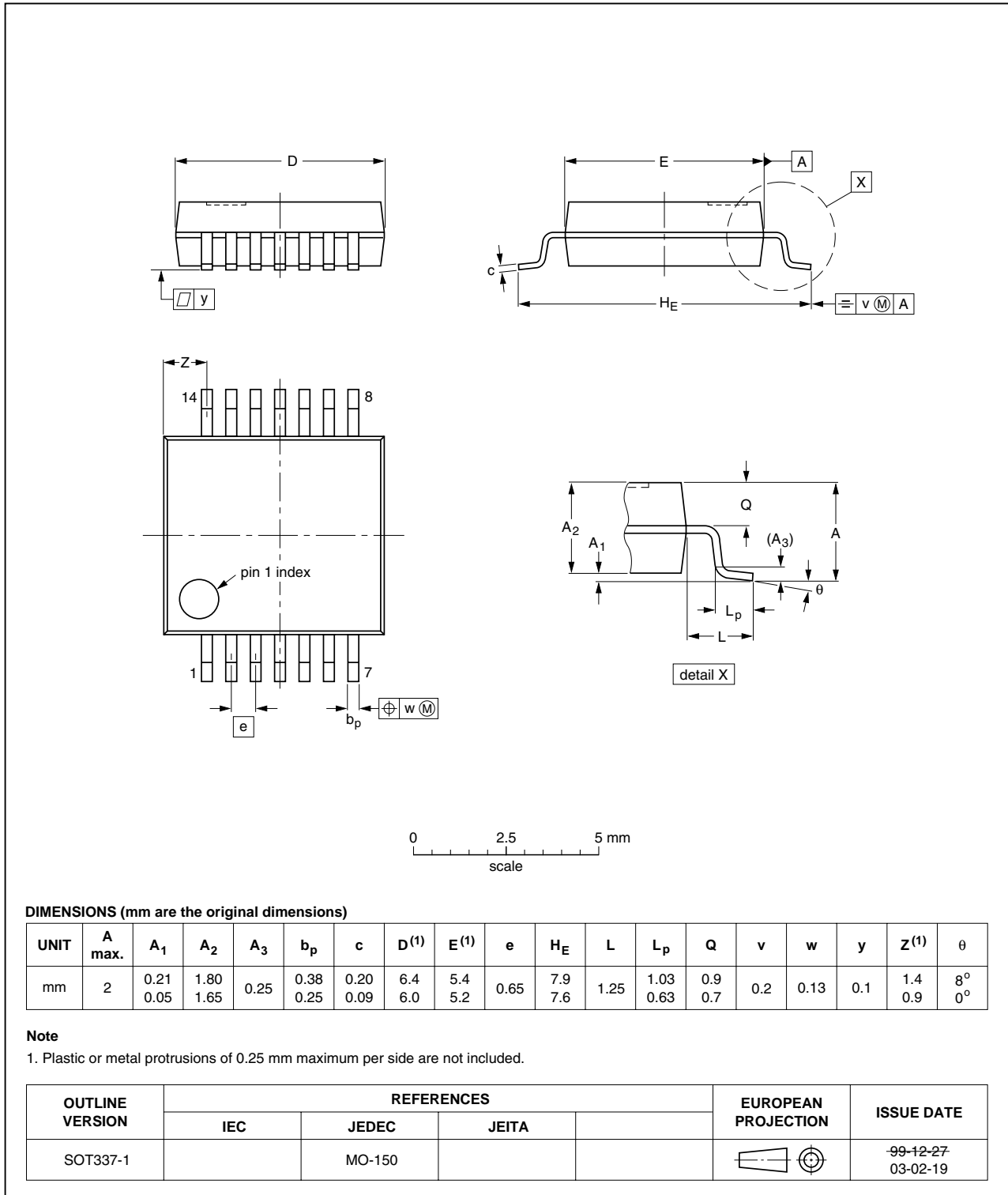

Fig 13. Package outline SOT337-1 (SSOP14)

TSSOP14: plastic thin shrink small outline package; 14 leads; body width 4.4 mm

SOT402-1

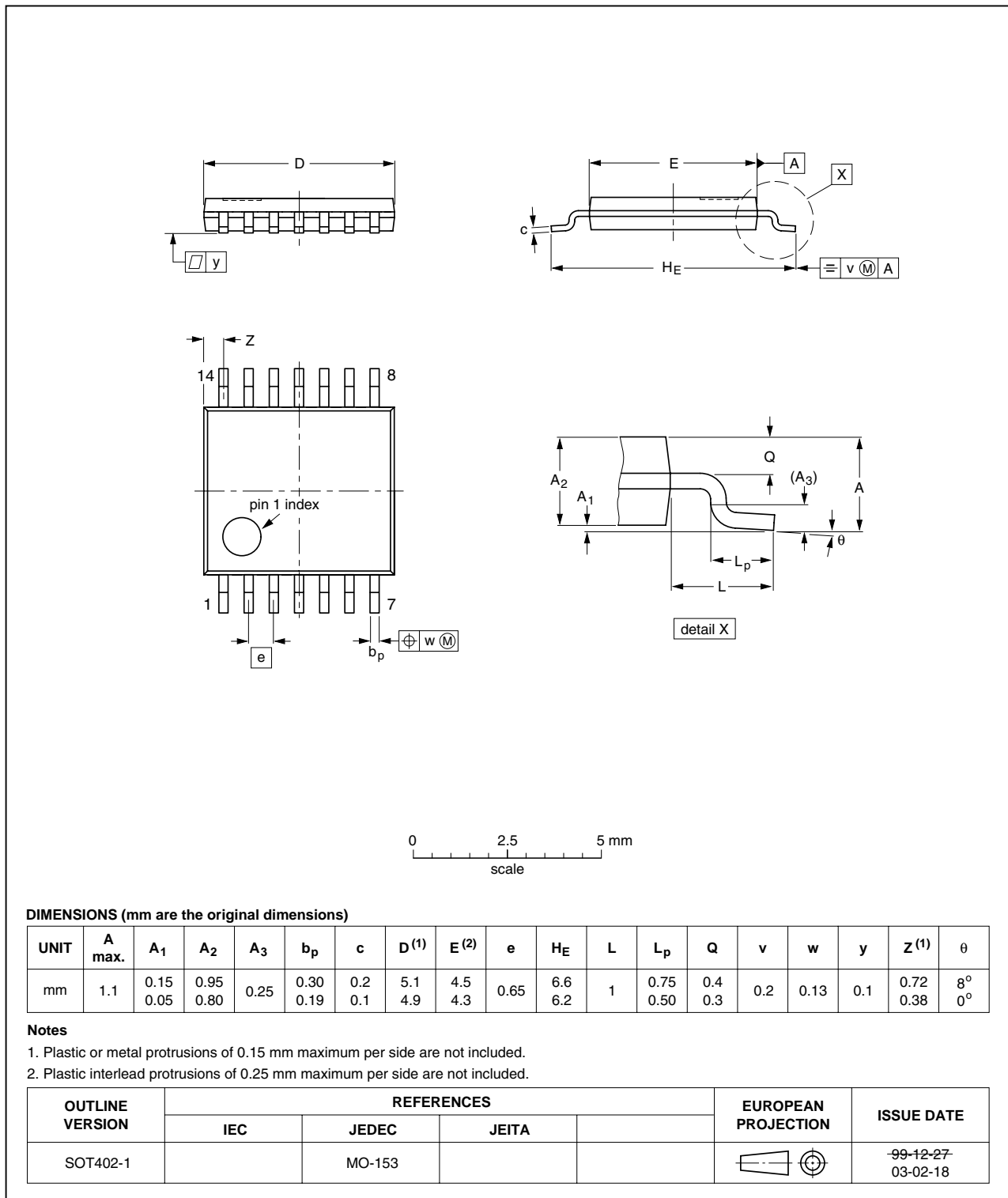
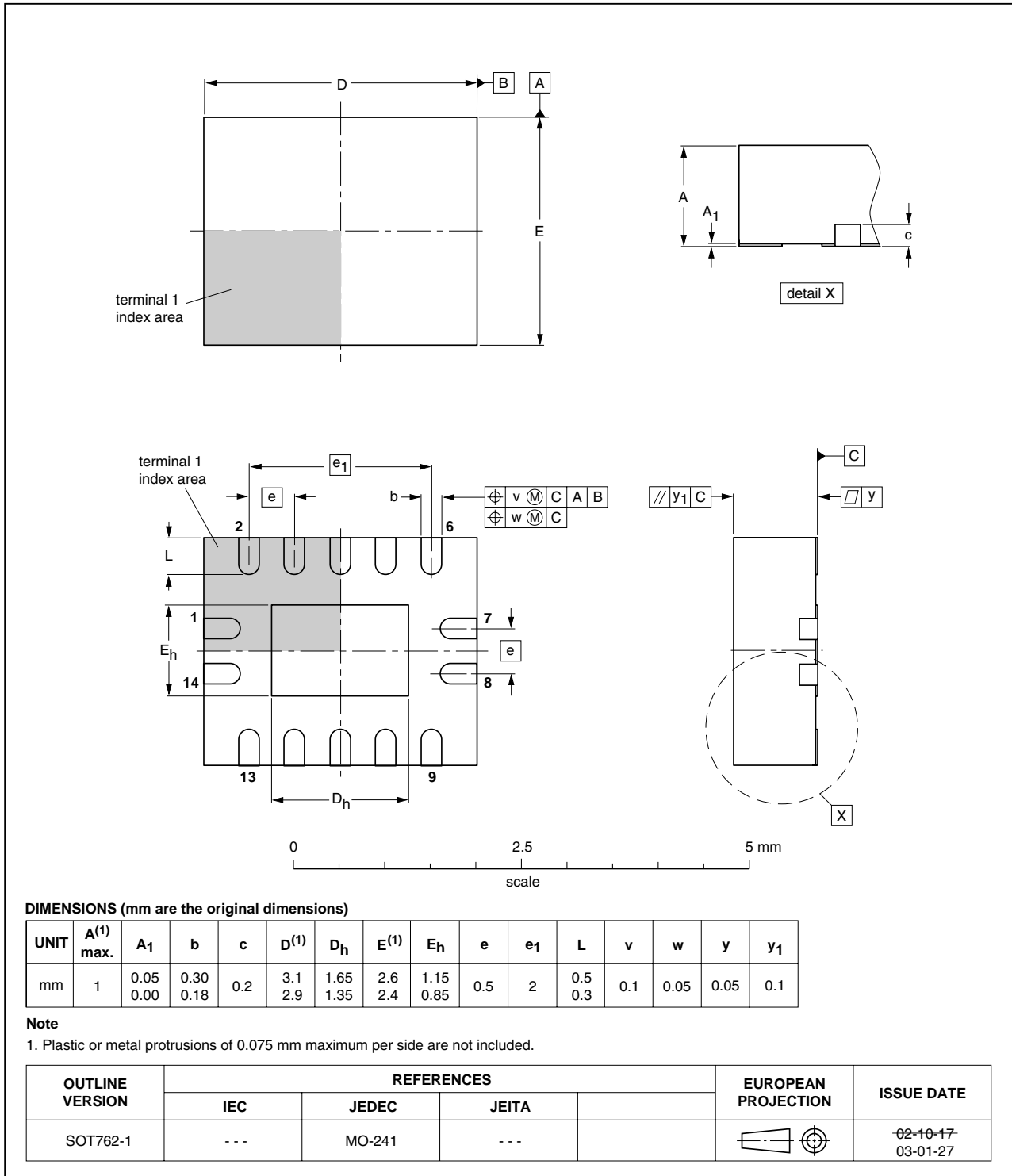

Fig 14. Package outline SOT402-1 (TSSOP14)

**DHVQFN14: plastic dual in-line compatible thermal enhanced very thin quad flat package; no leads; 14 terminals; body 2.5 x 3 x 0.85 mm**

**SOT762-1**



**Fig 15. Package outline SOT762-1 (DHVQFN14)**



## 12. Abbreviations

**Table 10. Abbreviations**

Acronym	Description
CMOS	Complementary Metal-Oxide Semiconductor
DUT	Device Under Test
ESD	ElectroStatic Discharge
HBM	Human Body Model
LSTTL	Low-power Schottky Transistor-Transistor Logic
MM	Machine Model
TTL	Transistor-Transistor Logic

## 13. Revision history

**Table 11. Revision history**

Document ID	Release date	Data sheet status	Change notice	Supersedes
74HC_HCT164_4	20100202	Product data sheet	-	74HC_HCT164_3
Modifications:	<ul style="list-style-type: none"> <li>The format of this data sheet has been redesigned to comply with the new identity guidelines of NXP Semiconductors.</li> <li>Legal texts have been adapted to the new company name where appropriate.</li> <li>Added type number 74HC164BQ (DHVQFN14 / SOT762-1 package).</li> <li>For type numbers 74HC164D and 74HCT164D: sot number SOT108-2 changed to SOT108-1.</li> </ul>			
74HC_HCT164_3	20050404	Product data sheet	-	74HC_HCT164_CNV_2
74HC_HCT164_CNV_2	19901201	Product specification	-	-

## 14. Legal information

### 14.1 Data sheet status

Document status <sup>[1][2]</sup>	Product status <sup>[3]</sup>	Definition
Objective [short] data sheet	Development	This document contains data from the objective specification for product development.
Preliminary [short] data sheet	Qualification	This document contains data from the preliminary specification.
Product [short] data sheet	Production	This document contains the product specification.

[1] Please consult the most recently issued document before initiating or completing a design.

[2] The term 'short data sheet' is explained in section "Definitions".

[3] The product status of device(s) described in this document may have changed since this document was published and may differ in case of multiple devices. The latest product status information is available on the Internet at URL <http://www.nxp.com>.

### 14.2 Definitions

**Draft** — The document is a draft version only. The content is still under internal review and subject to formal approval, which may result in modifications or additions. NXP Semiconductors does not give any representations or warranties as to the accuracy or completeness of information included herein and shall have no liability for the consequences of use of such information.

**Short data sheet** — A short data sheet is an extract from a full data sheet with the same product type number(s) and title. A short data sheet is intended for quick reference only and should not be relied upon to contain detailed and full information. For detailed and full information see the relevant full data sheet, which is available on request via the local NXP Semiconductors sales office. In case of any inconsistency or conflict with the short data sheet, the full data sheet shall prevail.

**Product specification** — The information and data provided in a Product data sheet shall define the specification of the product as agreed between NXP Semiconductors and its customer, unless NXP Semiconductors and customer have explicitly agreed otherwise in writing. In no event however, shall an agreement be valid in which the NXP Semiconductors product is deemed to offer functions and qualities beyond those described in the Product data sheet.

### 14.3 Disclaimers

**General** — Information in this document is believed to be accurate and reliable. However, NXP Semiconductors does not give any representations or warranties, expressed or implied, as to the accuracy or completeness of such information and shall have no liability for the consequences of use of such information.

**Right to make changes** — NXP Semiconductors reserves the right to make changes to information published in this document, including without limitation specifications and product descriptions, at any time and without notice. This document supersedes and replaces all information supplied prior to the publication hereof.

**Suitability for use** — NXP Semiconductors products are not designed, authorized or warranted to be suitable for use in medical, military, aircraft, space or life support equipment, nor in applications where failure or malfunction of an NXP Semiconductors product can reasonably be expected to result in personal injury, death or severe property or environmental damage. NXP Semiconductors accepts no liability for inclusion and/or use of NXP Semiconductors products in such equipment or applications and therefore such inclusion and/or use is at the customer's own risk.

**Applications** — Applications that are described herein for any of these products are for illustrative purposes only. NXP Semiconductors makes no representation or warranty that such applications will be suitable for the specified use without further testing or modification.

**Limiting values** — Stress above one or more limiting values (as defined in the Absolute Maximum Ratings System of IEC 60134) may cause permanent damage to the device. Limiting values are stress ratings only and operation of the device at these or any other conditions above those given in the Characteristics sections of this document is not implied. Exposure to limiting values for extended periods may affect device reliability.

**Terms and conditions of sale** — NXP Semiconductors products are sold subject to the general terms and conditions of commercial sale, as published at <http://www.nxp.com/profile/terms>, including those pertaining to warranty, intellectual property rights infringement and limitation of liability, unless explicitly otherwise agreed to in writing by NXP Semiconductors. In case of any inconsistency or conflict between information in this document and such terms and conditions, the latter will prevail.

**No offer to sell or license** — Nothing in this document may be interpreted or construed as an offer to sell products that is open for acceptance or the grant, conveyance or implication of any license under any copyrights, patents or other industrial or intellectual property rights.

**Export control** — This document as well as the item(s) described herein may be subject to export control regulations. Export might require a prior authorization from national authorities.

**Export control** — This document as well as the item(s) described herein may be subject to export control regulations. Export might require a prior authorization from national authorities.

**Non-automotive qualified products** — Unless the data sheet of an NXP Semiconductors product expressly states that the product is automotive qualified, the product is not suitable for automotive use. It is neither qualified nor tested in accordance with automotive testing or application requirements. NXP Semiconductors accepts no liability for inclusion and/or use of non-automotive qualified products in automotive equipment or applications.

In the event that customer uses the product for design-in and use in automotive applications to automotive specifications and standards, customer (a) shall use the product without NXP Semiconductors' warranty of the product for such automotive applications, use and specifications, and (b) whenever customer uses the product for automotive applications beyond NXP Semiconductors' specifications such use shall be solely at customer's own risk, and (c) customer fully indemnifies NXP Semiconductors for any liability, damages or failed product claims resulting from customer design and use of the product for automotive applications beyond NXP Semiconductors' standard warranty and NXP Semiconductors' product specifications.

### 14.4 Trademarks

Notice: All referenced brands, product names, service names and trademarks are the property of their respective owners.

## 15. Contact information

---

For sales office addresses, please send an email to: [info@sycelectronica.com.ar](mailto:info@sycelectronica.com.ar)

## 16. Contents

---

<b>1</b>	<b>General description</b> .....	<b>1</b>
<b>2</b>	<b>Features</b> .....	<b>1</b>
<b>3</b>	<b>Ordering information</b> .....	<b>2</b>
<b>4</b>	<b>Functional diagram</b> .....	<b>2</b>
<b>5</b>	<b>Pinning information</b> .....	<b>3</b>
5.1	Pinning .....	3
5.2	Pin description .....	4
<b>6</b>	<b>Functional description</b> .....	<b>4</b>
<b>7</b>	<b>Limiting values</b> .....	<b>4</b>
<b>8</b>	<b>Recommended operating conditions</b> .....	<b>5</b>
<b>9</b>	<b>Static characteristics</b> .....	<b>5</b>
<b>10</b>	<b>Dynamic characteristics</b> .....	<b>7</b>
<b>11</b>	<b>Package outline</b> .....	<b>12</b>
<b>12</b>	<b>Abbreviations</b> .....	<b>17</b>
<b>13</b>	<b>Revision history</b> .....	<b>17</b>
<b>14</b>	<b>Legal information</b> .....	<b>18</b>
14.1	Data sheet status .....	18
14.2	Definitions .....	18
14.3	Disclaimers .....	18
14.4	Trademarks .....	18
<b>15</b>	<b>Contact information</b> .....	<b>19</b>
<b>16</b>	<b>Contents</b> .....	<b>20</b>

founded by

**PHILIPS**