

## 4-Bit Magnitude Comparator

The SN74LS85 is a 4-Bit Magnitude Comparator which compares two 4-bit words (A, B), each word having four Parallel Inputs ( $A_0-A_3, B_0-B_3$ );  $A_3, B_3$  being the most significant inputs. Operation is not restricted to binary codes, the device will work with any monotonic code. Three Outputs are provided: “A greater than B” ( $O_{A>B}$ ), “A less than B” ( $O_{A<B}$ ), “A equal to B” ( $O_{A=B}$ ). Three Expander Inputs,  $I_{A>B}, I_{A<B}, I_{A=B}$ , allow cascading without external gates. For proper compare operation, the Expander Inputs to the least significant position must be connected as follows:  $I_{A<B} = I_{A>B} = L$ ,  $I_{A=B} = H$ . For serial (ripple) expansion, the  $O_{A>B}, O_{A<B}$  and  $O_{A=B}$  Outputs are connected respectively to the  $I_{A>B}, I_{A<B}$ , and  $I_{A=B}$  Inputs of the next most significant comparator, as shown in Figure 1. Refer to Applications section of data sheet for high speed method of comparing large words.

The Truth Table on the following page describes the operation of the SN74LS85 under all possible logic conditions. The upper 11 lines describe the normal operation under all conditions that will occur in a single device or in a series expansion scheme. The lower five lines describe the operation under abnormal conditions on the cascading inputs. These conditions occur when the parallel expansion technique is used.

- Easily Expandable
- Binary or BCD Comparison
- $O_{A>B}, O_{A<B}$ , and  $O_{A=B}$  Outputs Available

### GUARANTEED OPERATING RANGES

Symbol	Parameter	Min	Typ	Max	Unit
$V_{CC}$	Supply Voltage	4.75	5.0	5.25	V
$T_A$	Operating Ambient Temperature Range	0	25	70	°C
$I_{OH}$	Output Current – High			-0.4	mA
$I_{OL}$	Output Current – Low			8.0	mA

## 74LS85

**LOW  
POWER  
SCHOTTKY**

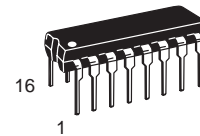

**PLASTIC  
N SUFFIX  
CASE 648**

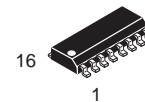

**SOIC  
D SUFFIX  
CASE 751B**

### ORDERING INFORMATION

Device	Package	Shipping
SN74LS85N	16 Pin DIP	
SN74LS85D	16 Pin	

# SN74LS85

## CONNECTION DIAGRAM DIP (TOP VIEW)

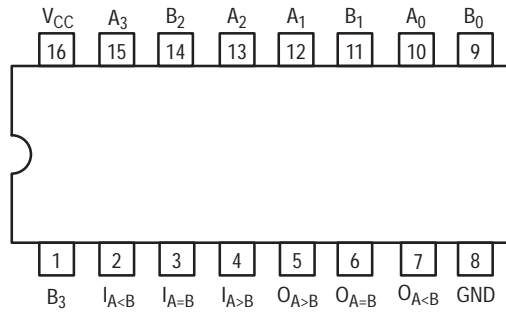

NOTE:  
The Flatpak version has the same pinouts (Connection Diagram) as the Dual In-Line Package.

PIN NAMES		LOADING (Note a)	
		HIGH	LOW
$A_0 - A_3, B_0 - B_3$	Parallel Inputs	1.5 U.L.	0.75 U.L.
$I_{A=B}$	A = B Expander Inputs	1.5 U.L.	0.75 U.L.
$I_{A<B}, I_{A>B}$	A < B, A > B, Expander Inputs	0.5 U.L.	0.25 U.L.
$O_{A>B}$	A Greater than B Output	10 U.L.	5 U.L.
$O_{A<B}$	B Greater than A Output	10 U.L.	5 U.L.
$O_{A=B}$	A Equal to B Output	10 U.L.	5 U.L.

### NOTES:

a) 1 TTL Unit Load (U.L.) = 40  $\mu$ A HIGH/1.6 mA LOW.

## LOGIC SYMBOL

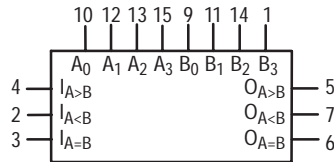

$V_{CC}$  = PIN 16  
GND = PIN 8

# SN74LS85

## LOGIC DIAGRAM

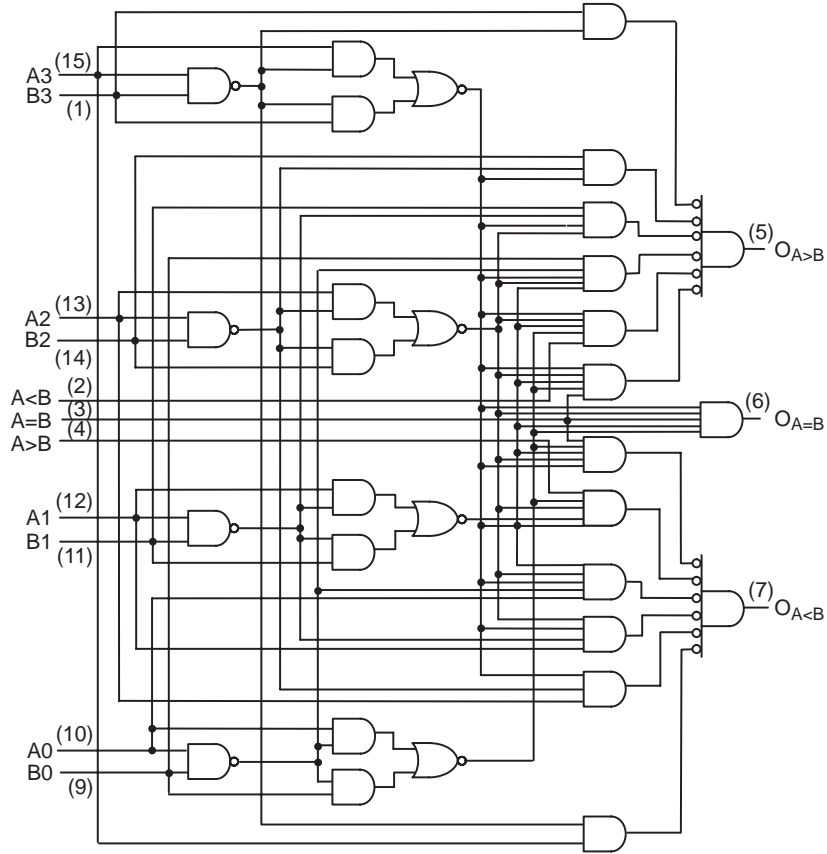

## TRUTH TABLE

COMPARING INPUTS				CASCADING INPUTS			OUTPUTS		
A <sub>3</sub> ,B <sub>3</sub>	A <sub>2</sub> ,B <sub>2</sub>	A <sub>1</sub> ,B <sub>1</sub>	A <sub>0</sub> ,B <sub>0</sub>	I <sub>A&gt;B</sub>	I <sub>A&lt;B</sub>	I <sub>A=B</sub>	O <sub>A&gt;B</sub>	O <sub>A&lt;B</sub>	O <sub>A=B</sub>
A <sub>3</sub> >B <sub>3</sub>	X	X	X	X	X	X	H	L	L
A <sub>3</sub> <B <sub>3</sub>	X	X	X	X	X	X	L	H	L
A <sub>3</sub> =B <sub>3</sub>	A <sub>2</sub> >B <sub>2</sub>	X	X	X	X	X	H	L	L
A <sub>3</sub> =B <sub>3</sub>	A <sub>2</sub> <B <sub>2</sub>	X	X	X	X	X	L	H	L
A <sub>3</sub> =B <sub>3</sub>	A <sub>2</sub> =B <sub>2</sub>	A <sub>1</sub> >B <sub>1</sub>	X	X	X	X	H	L	L
A <sub>3</sub> =B <sub>3</sub>	A <sub>2</sub> =B <sub>2</sub>	A <sub>1</sub> <B <sub>1</sub>	X	X	X	X	L	H	L
A <sub>3</sub> =B <sub>3</sub>	A <sub>2</sub> =B <sub>2</sub>	A <sub>1</sub> =B <sub>1</sub>	A <sub>0</sub> >B <sub>0</sub>	X	X	X	H	L	L
A <sub>3</sub> =B <sub>3</sub>	A <sub>2</sub> =B <sub>2</sub>	A <sub>1</sub> =B <sub>1</sub>	A <sub>0</sub> <B <sub>0</sub>	X	X	X	L	H	L
A <sub>3</sub> =B <sub>3</sub>	A <sub>2</sub> =B <sub>2</sub>	A <sub>1</sub> =B <sub>1</sub>	A <sub>0</sub> =B <sub>0</sub>	H	L	L	H	L	L
A <sub>3</sub> =B <sub>3</sub>	A <sub>2</sub> =B <sub>2</sub>	A <sub>1</sub> =B <sub>1</sub>	A <sub>0</sub> =B <sub>0</sub>	L	H	L	L	H	L
A <sub>3</sub> =B <sub>3</sub>	A <sub>2</sub> =B <sub>2</sub>	A <sub>1</sub> =B <sub>1</sub>	A <sub>0</sub> =B <sub>0</sub>	X	X	H	L	L	H
A <sub>3</sub> =B <sub>3</sub>	A <sub>2</sub> =B <sub>2</sub>	A <sub>1</sub> =B <sub>1</sub>	A <sub>0</sub> =B <sub>0</sub>	H	H	L	L	L	L
A <sub>3</sub> =B <sub>3</sub>	A <sub>2</sub> =B <sub>2</sub>	A <sub>1</sub> =B <sub>1</sub>	A <sub>0</sub> =B <sub>0</sub>	L	L	L	H	H	L

H = HIGH Level  
 L = LOW Level  
 X = IMMATERIAL

# SN74LS85

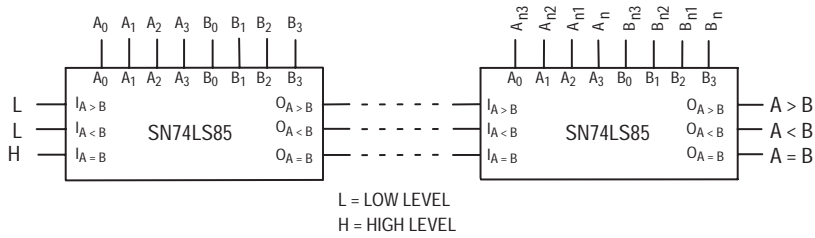

Figure 1. Comparing Two n-Bit Words

## APPLICATIONS

Figure 2 shows a high speed method of comparing two 24-bit words with only two levels of device delay. With the technique shown in Figure 1, six levels of device delay result

when comparing two 24-bit words. The parallel technique can be expanded to any number of bits, see Table 1.

Table 1

WORD LENGTH	NUMBER OF PKGS.
1-4 Bits	1
5-24 Bits	2-6
25-120 Bits	8-31

NOTE:

The SN74LS85 can be used as a 5-bit comparator only when the outputs are used to drive the A<sub>0</sub>-A<sub>3</sub> and B<sub>0</sub>-B<sub>3</sub> inputs of another SN74LS85 as shown in Figure 2 in positions #1, 2, 3, and 4.

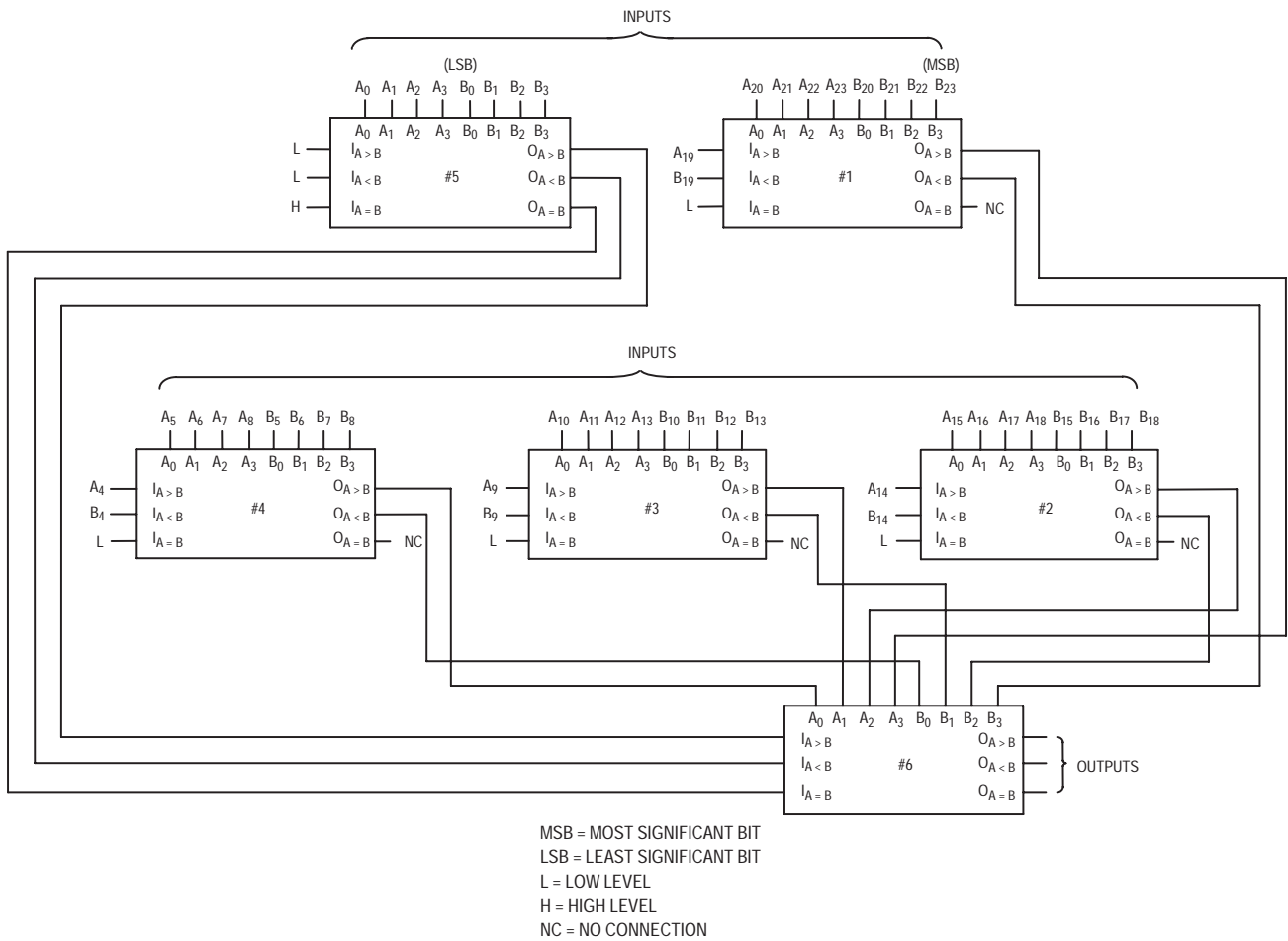

Figure 2. Comparison of Two 24-Bit Words

# SN74LS85

## DC CHARACTERISTICS OVER OPERATING TEMPERATURE RANGE (unless otherwise specified)

Symbol	Parameter	Limits			Unit	Test Conditions
		Min	Typ	Max		
$V_{IH}$	Input HIGH Voltage	2.0			V	Guaranteed Input HIGH Voltage for All Inputs
$V_{IL}$	Input LOW Voltage			0.8	V	Guaranteed Input LOW Voltage for All Inputs
$V_{IK}$	Input Clamp Diode Voltage		-0.65	-1.5	V	$V_{CC} = \text{MIN}$ , $I_{IN} = -18 \text{ mA}$
$V_{OH}$	Output HIGH Voltage	2.7	3.5		V	$V_{CC} = \text{MIN}$ , $I_{OH} = \text{MAX}$ , $V_{IN} = V_{IH}$ or $V_{IL}$ per Truth Table
$V_{OL}$	Output LOW Voltage		0.25	0.4	V	$V_{CC} = V_{CC} \text{ MIN}$ , $V_{IN} = V_{IL}$ or $V_{IH}$ per Truth Table
			0.35	0.5	V	
$I_{IH}$	Input HIGH Current A < B, A > B Other Inputs			20 60	$\mu\text{A}$	$V_{CC} = \text{MAX}$ , $V_{IN} = 2.7 \text{ V}$
	A < B, A > B Other Inputs			0.1 0.3	mA	$V_{CC} = \text{MAX}$ , $V_{IN} = 7.0 \text{ V}$
$I_{IL}$	Input LOW Current A < B, A > B Other Inputs			-0.4 -1.2	mA	$V_{CC} = \text{MAX}$ , $V_{IN} = 0.4 \text{ V}$
$I_{OS}$	Output Short Circuit Current (Note 1)	-20		-100	mA	$V_{CC} = \text{MAX}$
$I_{CC}$	Power Supply Current			20	mA	$V_{CC} = \text{MAX}$

Note 1: Not more than one output should be shorted at a time, nor for more than 1 second.

## AC CHARACTERISTICS ( $T_A = 25^\circ\text{C}$ , $V_{CC} = 5.0 \text{ V}$ )

Symbol	Parameter	Limits			Unit	Test Conditions
		Min	Typ	Max		
$t_{PLH}$ $t_{PHL}$	Any A or B to A < B, A > B		24 20	36 30	ns	$V_{CC} = 5.0 \text{ V}$ $C_L = 15 \text{ pF}$
$t_{PLH}$ $t_{PHL}$	Any A or B to A = B		27 23	45 45	ns	
$t_{PLH}$ $t_{PHL}$	A < B or A = B to A > B		14 11	22 17	ns	
$t_{PLH}$ $t_{PHL}$	A = B to A = B		13 13	20 26	ns	
$t_{PLH}$ $t_{PHL}$	A > B or A = B to A < B		14 11	22 17	ns	

## AC WAVEFORMS

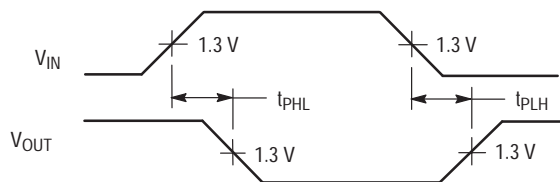

Figure 3.

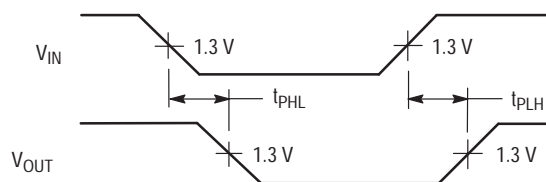
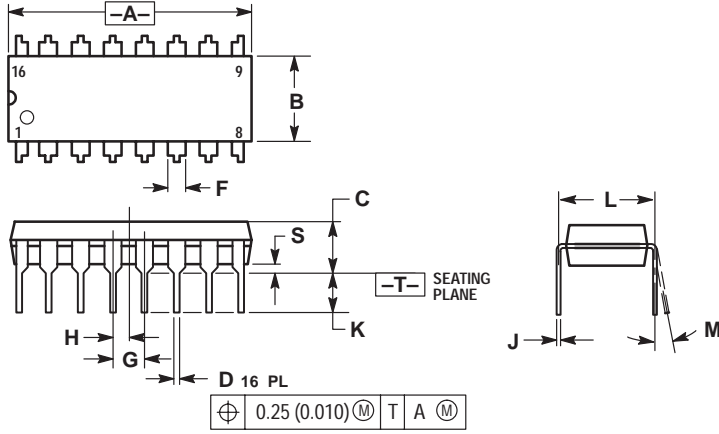

Figure 4.

# SN74LS85

## PACKAGE DIMENSIONS

**N SUFFIX**  
**PLASTIC PACKAGE**  
**CASE 648-08**  
**ISSUE R**



**NOTES:**

1. DIMENSIONING AND TOLERANCING PER ANSI Y14.5M, 1982.
2. CONTROLLING DIMENSION: INCH.
3. DIMENSION L TO CENTER OF LEADS WHEN FORMED PARALLEL.
4. DIMENSION B DOES NOT INCLUDE MOLD FLASH.
5. ROUNDED CORNERS OPTIONAL.

DIM	INCHES		MILLIMETERS	
	MIN	MAX	MIN	MAX
A	0.740	0.770	18.80	19.55
B	0.250	0.270	6.35	6.85
C	0.145	0.175	3.69	4.44
D	0.015	0.021	0.39	0.53
F	0.040	0.70	1.02	1.77
G	0.100 BSC		2.54 BSC	
H	0.050 BSC		1.27 BSC	
J	0.008	0.015	0.21	0.38
K	0.110	0.130	2.80	3.30
L	0.295	0.305	7.50	7.74
M	0° 10°		0° 10°	
S	0.020	0.040	0.51	1.01

# SN74LS85

## PACKAGE DIMENSIONS

### D SUFFIX PLASTIC SOIC PACKAGE CASE 751B-05 ISSUE J

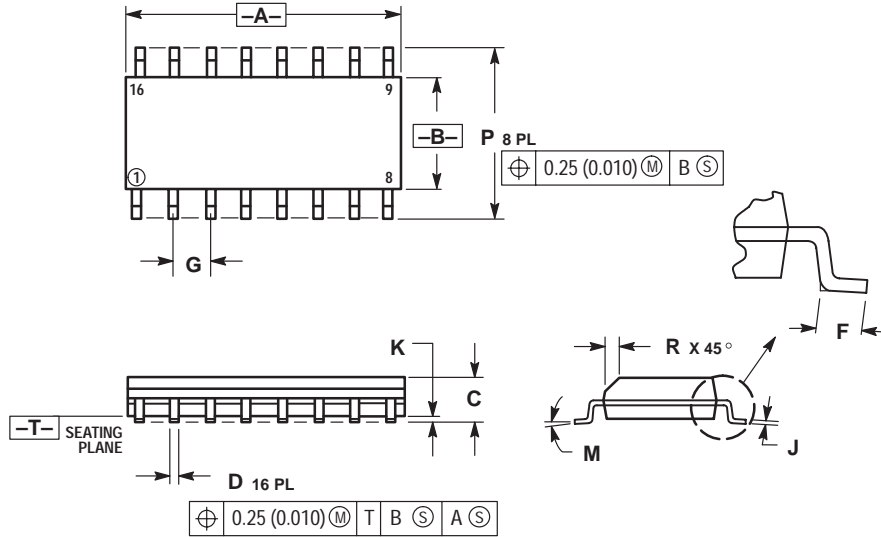

#### NOTES:

1. DIMENSIONING AND TOLERANCING PER ANSI Y14.5M, 1982.
2. CONTROLLING DIMENSION: MILLIMETER.
3. DIMENSIONS A AND B DO NOT INCLUDE MOLD PROTRUSION.
4. MAXIMUM MOLD PROTRUSION 0.15 (0.006) PER SIDE.
5. DIMENSION D DOES NOT INCLUDE DAMBAR PROTRUSION. ALLOWABLE DAMBAR PROTRUSION SHALL BE 0.127 (0.005) TOTAL IN EXCESS OF THE D DIMENSION AT MAXIMUM MATERIAL CONDITION.

DIM	MILLIMETERS		INCHES	
	MIN	MAX	MIN	MAX
A	9.80	10.00	0.386	0.393
B	3.80	4.00	0.150	0.157
C	1.35	1.75	0.054	0.068
D	0.35	0.49	0.014	0.019
F	0.40	1.25	0.016	0.049
G	1.27 BSC		0.050 BSC	
J	0.19	0.25	0.008	0.009
K	0.10	0.25	0.004	0.009
M	0°	7°	0°	7°
P	5.80	6.20	0.229	0.244
R	0.25	0.50	0.010	0.019