

# GENERAL PURPOSE 6-PIN PHOTODARLINGTON OPTOCOUPLERS

## DESCRIPTION

The 4N29, 4N30, 4N31, 4N32, 4N33 have a gallium arsenide infrared emitter optically coupled to a silicon planar photodarlington.

4N29    4N30    4N31    4N32    4N33

## FEATURES

- High sensitivity to low input drive current
- Meets or exceeds all JEDEC Registered Specifications
- VDE 0884 approval available as a test option  
-add option .300. (e.g., 4N29.300)

## APPLICATIONS

- Low power logic circuits
- Telecommunications equipment
- Portable electronics
- Solid state relays
- Interfacing coupling systems of different potentials and impedances.

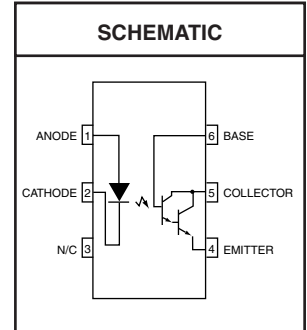
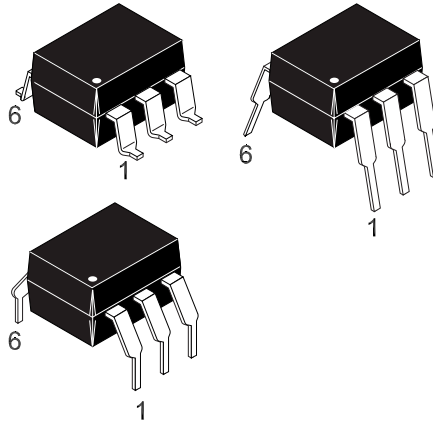

## ABSOLUTE MAXIMUM RATINGS ( $T_A = 25^\circ\text{C}$ Unless otherwise specified.)

Parameter	Symbol	Value	Units
<b>TOTAL DEVICE</b>			
Storage Temperature	$T_{STG}$	-55 to +150	$^\circ\text{C}$
Operating Temperature	$T_{OPR}$	-55 to +100	$^\circ\text{C}$
Lead Solder Temperature	$T_{SOL}$	260 for 10 sec	$^\circ\text{C}$
Total Device Power Dissipation @ $T_A = 25^\circ\text{C}$	$P_D$	250	mW
Derate above $25^\circ\text{C}$		3.3	mW/ $^\circ\text{C}$
<b>EMITTER</b>			
Continuous Forward Current	$I_F$	80	mA
Reverse Voltage	$V_R$	3	V
Forward Current - Peak (300 $\mu\text{s}$ , 2% Duty Cycle)	$I_F(\text{pk})$	3.0	A
LED Power Dissipation @ $T_A = 25^\circ\text{C}$	$P_D$	150	mW
Derate above $25^\circ\text{C}$		2.0	mW/ $^\circ\text{C}$
<b>DETECTOR</b>			
Collector-Emitter Breakdown Voltage	$BV_{CEO}$	30	V
Collector-Base Breakdown Voltage	$BV_{CBO}$	30	V
Emitter-Collector Breakdown Voltage	$BV_{ECO}$	5	V
Detector Power Dissipation @ $T_A = 25^\circ\text{C}$	$P_D$	150	mW
Derate above $25^\circ\text{C}$		2.0	mW/ $^\circ\text{C}$
Continuous Collector Current	$I_C$	150	mA

# GENERAL PURPOSE 6-PIN PHOTODARLINGTON OPTOCOUPLEDERS

<b>4N29</b>	<b>4N30</b>	<b>4N31</b>	<b>4N32</b>	<b>4N33</b>
-------------	-------------	-------------	-------------	-------------

## ELECTRICAL CHARACTERISTICS (T<sub>A</sub> = 25°C Unless otherwise specified.)

### INDIVIDUAL COMPONENT CHARACTERISTICS

Parameter	Test Conditions	Symbol	Min	Typ	Max	Unit
<b>EMITTER</b>						
*Input Forward Voltage	(I <sub>F</sub> = 10 mA)	V <sub>F</sub>		1.2	1.5	V
*Reverse Leakage Current	(V <sub>R</sub> = 3.0 V)	I <sub>R</sub>		0.001	100	μA
*Capacitance	(V <sub>F</sub> = 0 V, f = 1.0 MHz)	C		150		pF
<b>DETECTOR</b>						
*Collector-Emitter Breakdown Voltage	(I <sub>C</sub> = 100 μA, I <sub>B</sub> = 0)	BV <sub>CEO</sub>	30	60		
*Collector-Base Breakdown Voltage	(I <sub>C</sub> = 100 μA, I <sub>E</sub> = 0)	BV <sub>CBO</sub>	30	100		V
*Emitter-Collector Breakdown Voltage	(I <sub>E</sub> = 100 μA, I <sub>B</sub> = 0)	BV <sub>ECO</sub>	5.0	8		V
*Collector-Emitter Dark Current	(V <sub>CE</sub> = 10 V, Base Open)	I <sub>CEO</sub>		1	100	nA
DC Current Gain	(V <sub>CE</sub> = 5.0 V, I <sub>C</sub> = 500 μA)	h <sub>FE</sub>		5000		

### TRANSFER CHARACTERISTICS

DC Characteristic	Test Conditions	Symbol	Min	Typ	Max	Units
*Collector Output Current <sup>(1,2)</sup> (4N32, 4N33) (4N29, 4N30) (4N31)	(I <sub>F</sub> = 10 mA, V <sub>CE</sub> = 10 V, I <sub>B</sub> = 0)	I <sub>C</sub> (CTR)	50 (500)			mA (%)
			10 (100)			
			5 (50)			
*Saturation Voltage <sup>(2)</sup> (4N29, 4N30, 4N32, 4N33) (4N31)	(I <sub>F</sub> = 8.0 mA, I <sub>C</sub> = 2.0 mA)	V <sub>CE(sat)</sub>			1.0	V
					1.2	

### TRANSFER CHARACTERISTICS

AC Characteristic	Test Conditions	Symbol	Min	Typ	Max	Units
Turn-on Time <sup>(3)</sup>	(I <sub>F</sub> = 200 mA, I <sub>C</sub> = 50 mA, V <sub>CC</sub> = 10 V) (Fig.7)	t <sub>on</sub>			5.0	μs
Turn-off Time <sup>(3)</sup> (4N32, 4N33)					100	
(4N29, 4N30, 4N31)					40	
Bandwidth <sup>(4,5)</sup>		BW		30		KHz

### ISOLATION CHARACTERISTICS

Characteristic	Test Conditions	Symbol	Min	Typ	Max	Units
Input-Output Isolation Voltage <sup>(6)</sup> (4N29, 4N30, 4N31, 4N32, 4N33)	(I <sub>I-O</sub> ≤ 1 μA, V <sub>rms</sub> , t = 1 min.)	V <sub>ISO</sub>	5300			Vac(rms)
* (4N32)			VDC	2500		V
* (4N33)			VDC	1500		
Isolation Resistance <sup>(6)</sup>	(V <sub>I-O</sub> = 500 VDC)	R <sub>ISO</sub>		10 <sup>11</sup>		Ω
Isolation Capacitance <sup>(6)</sup>	(V <sub>I-O</sub> = ∅, f = 1 MHz)	C <sub>ISO</sub>		0.8		pf

# GENERAL PURPOSE 6-PIN PHOTODARLINGTON OPTOCOUPLERS

4N29 4N30 4N31 4N32 4N33

Fig. 1 Output Current vs. Input Current

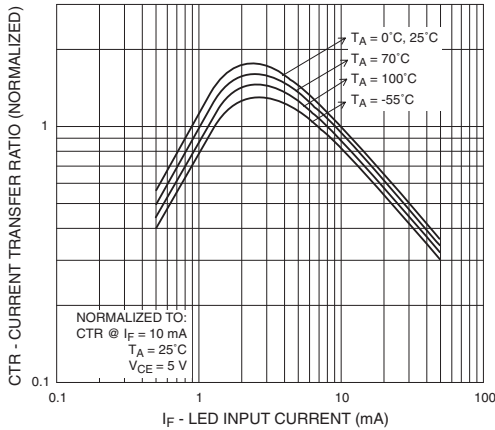

Fig. 2 Current Transfer Ratio vs. Ambient Temperature

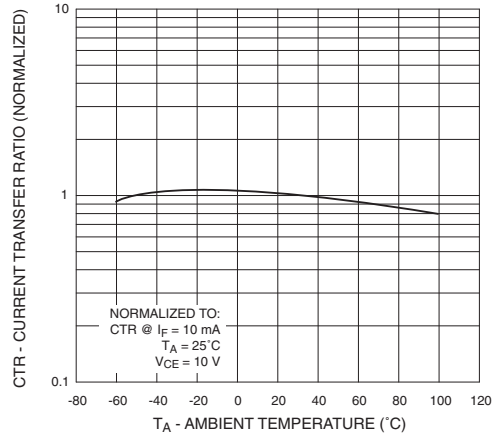

Fig. 3 Collector Current vs. Collector-Emitter Voltage

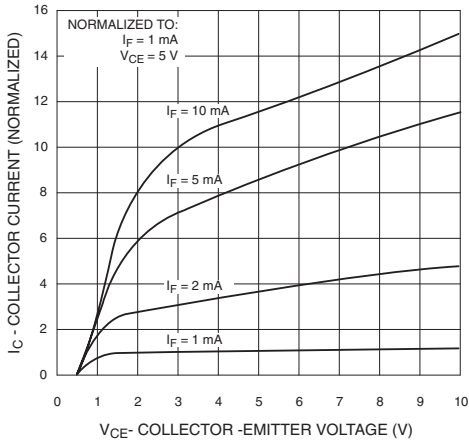

Fig. 4 Dark Current vs. Ambient Temperature

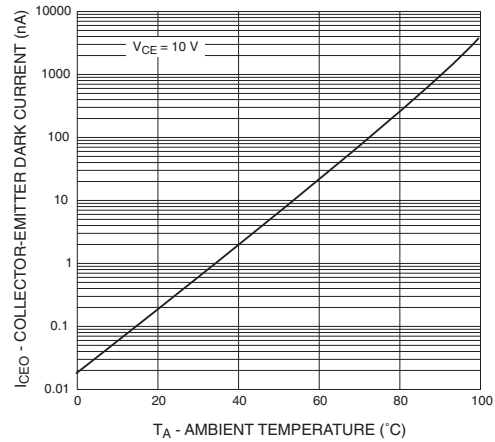

Fig. 5 Turn-On Time vs. Input Current

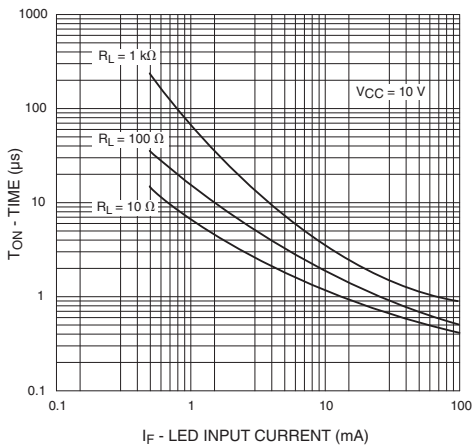
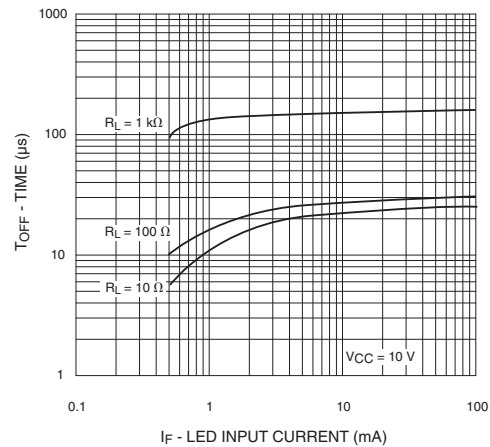

Fig. 6 Turn-Off Time vs. Input Current



# GENERAL PURPOSE 6-PIN PHOTODARLINGTON OPTOCOUPLERS

4N29 4N30 4N31 4N32 4N33

## TYPICAL ELECTRO-OPTICAL CHARACTERISTIC CURVES

(25°C Free air temperature unless otherwise specified) (Cont.)

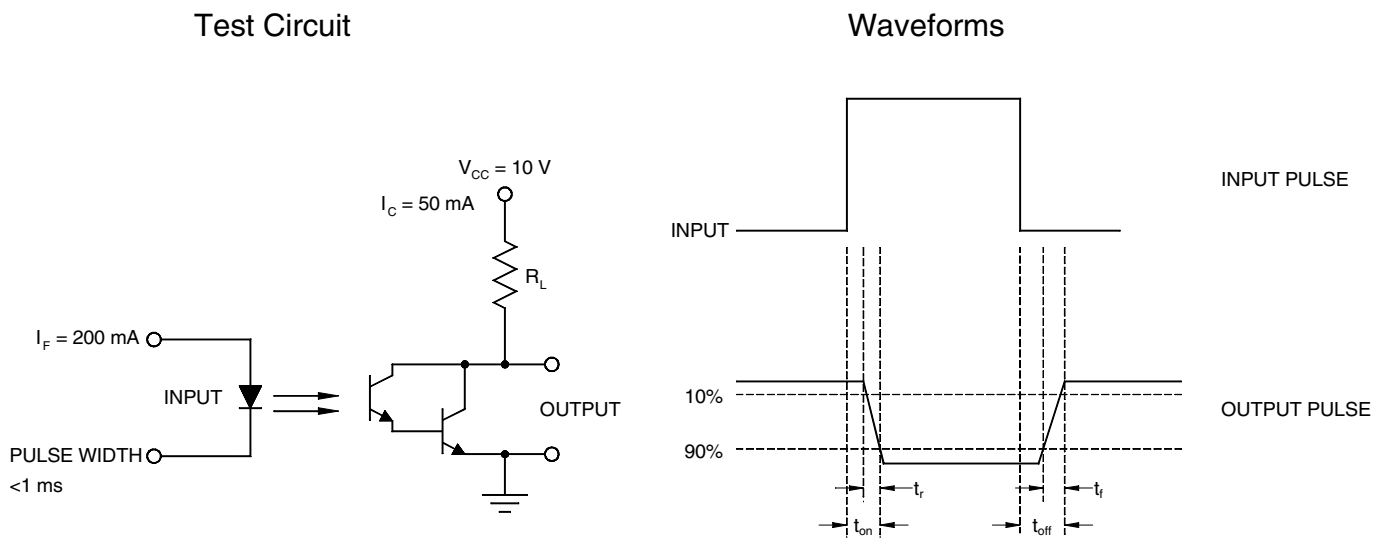

Fig. 7 Switching Time Test Circuit and Waveforms

### Notes

\* Indicates JEDEC registered data.

1. The current transfer ratio ( $I_C/I_F$ ) is the ratio of the detector collector current to the LED input current with  $V_{CE}$  @ 10 V.
2. Pulse test: pulse width =  $300\mu\text{s}$ , duty cycle  $\leq 2.0\%$ .
3. For test circuit setup and waveforms, refer to figure 7..
4.  $I_F$  adjusted to  $I_C = 2.0\text{ mA}$  and  $I_C = 0.7\text{ mA rms}$ .
5. The frequency at which  $I_C$  is 3dB down from the 1 KHz value.
6. For this test, LED pins 1 and 2 are common, and phototransistor pins 4,5 and 6 are common.

# GENERAL PURPOSE 6-PIN PHOTODARLINGTON OPTOCOUPPLERS

4N29 4N30 4N31 4N32 4N33

## Package Dimensions (Through Hole)

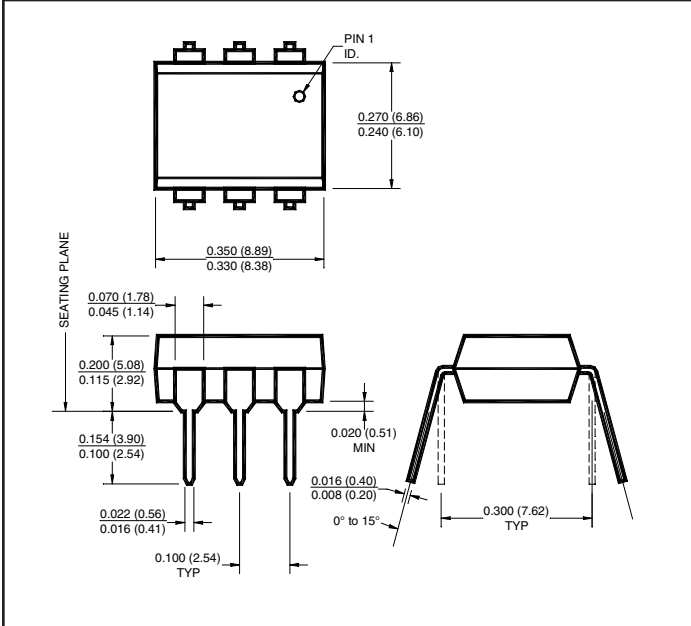

## Package Dimensions (Surface Mount)

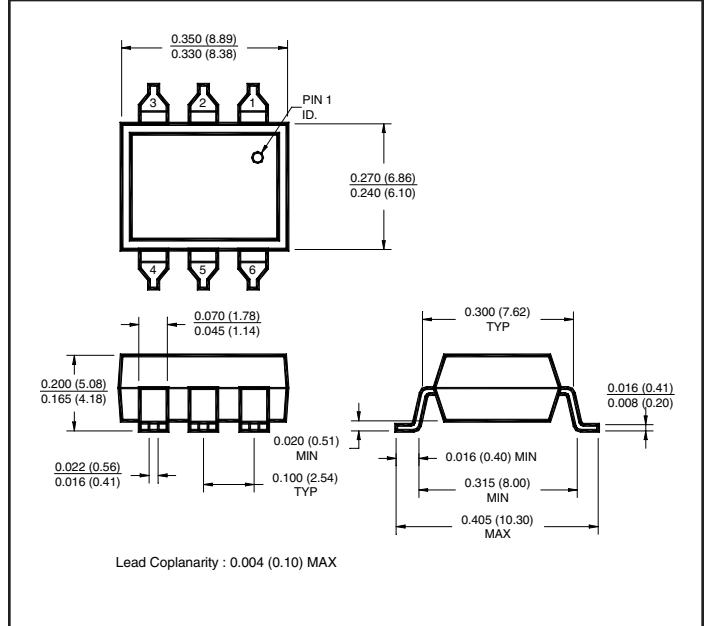

## Package Dimensions (0.4" Lead Spacing)

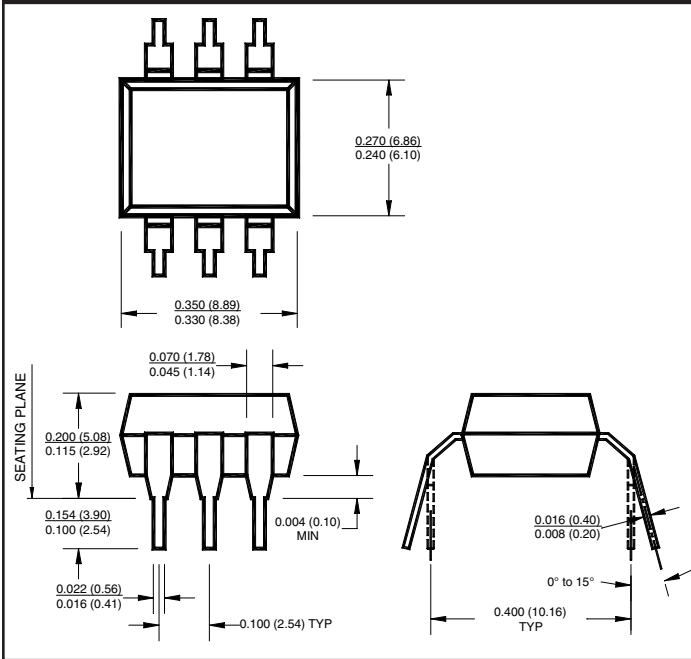

## Recommended Pad Layout for Surface Mount Leadform

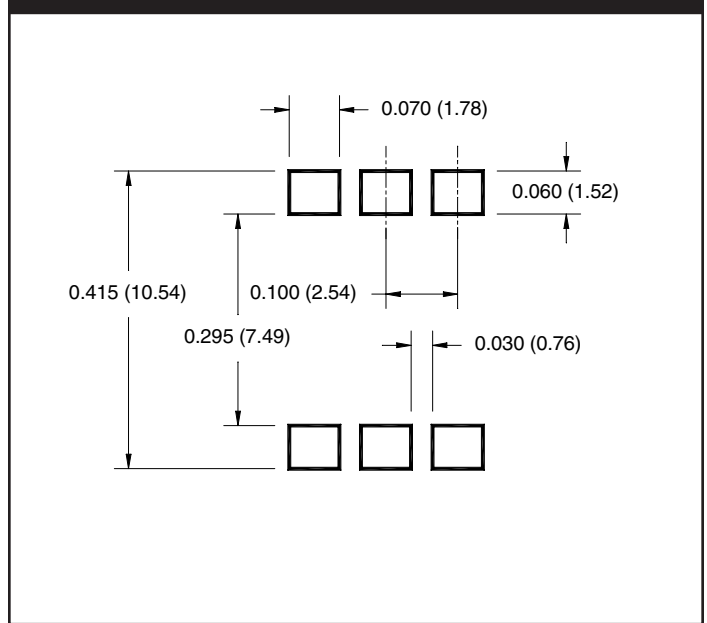

### NOTE

All dimensions are in inches (millimeters)

# GENERAL PURPOSE 6-PIN PHOTODARLINGTON OPTOCOUPPLERS

4N29	4N30	4N31	4N32	4N33
------	------	------	------	------

## ORDERING INFORMATION

Option	Order Entry Identifier	Description
S	.S	Surface Mount Lead Bend
SD	.SD	Surface Mount; Tape and reel
W	.W	0.4" Lead Spacing
300	.300	VDE 0884
300W	.300W	VDE 0884, 0.4" Lead Spacing
3S	.3S	VDE 0884, Surface Mount
3SD	.3SD	VDE 0884, Surface Mount, Tape & Reel

## QT Carrier Tape Specifications ("D" Taping Orientation)

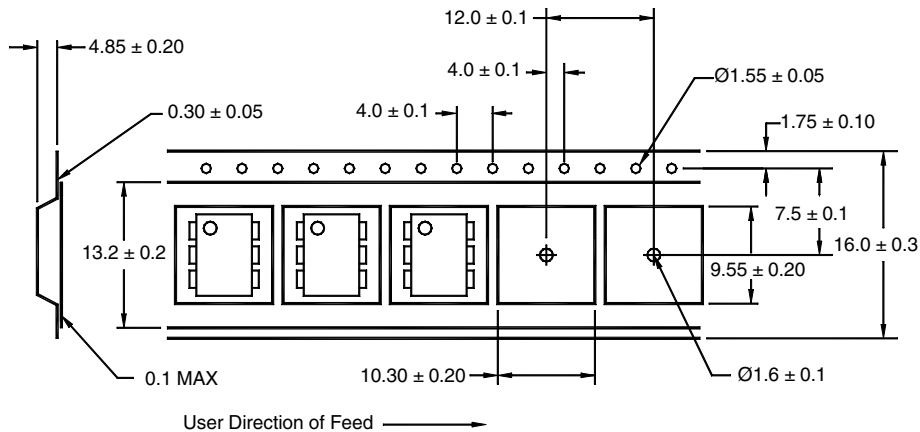

### NOTE

All dimensions are in millimeters