

# LM747 Dual Operational Amplifier

## General Description

The LM747 is a general purpose dual operational amplifier. The two amplifiers share a common bias network and power supply leads. Otherwise, their operation is completely independent.

Additional features of the LM747 are: no latch-up when input common mode range is exceeded, freedom from oscillations, and package flexibility.

The LM747C/LM747E is identical to the LM747/LM747A except that the LM747C/LM747E has its specifications guaranteed over the temperature range from 0°C to +70°C instead of -55°C to +125°C.

## Features

- No frequency compensation required
- Short-circuit protection
- Wide common-mode and differential voltage ranges
- Low power consumption
- No latch-up
- Balanced offset null

## Connection Diagrams

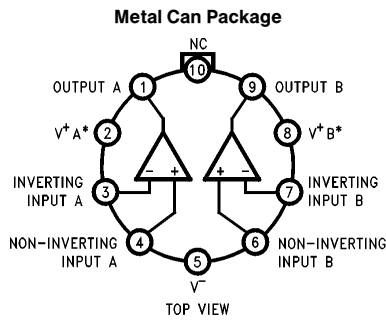

TL/H/11479-4

**Order Number LM747H**  
**See NS Package Number H10C**

\*V<sup>+</sup>A and V<sup>+</sup>B are internally connected.

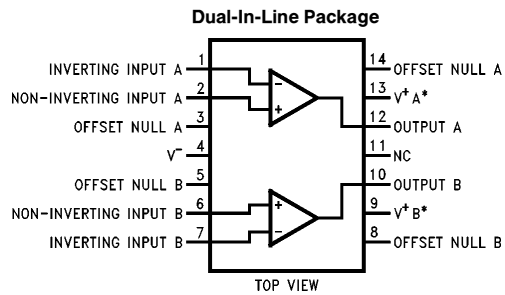

TL/H/11479-5

**Order Number LM747CN or LM747EN**  
**See NS Package Number N14A**

## Absolute Maximum Ratings

If Military/Aerospace specified devices are required, please contact the National Semiconductor Sales Office/Distributors for availability and specifications.

Supply Voltage	
LM747/LM747A	±22V
LM747C/LM747E	±18V
Power Dissipation (Note 1)	800 mW
Differential Input Voltage	±30V

Input Voltage (Note 2)	±15V
Output Short-Circuit Duration	Indefinite
Operating Temperature Range	
LM747/LM747A	-55°C to +125°C
LM747C/LM747E	0°C to +70°C
Storage Temperature Range	-65°C to +150°C
Lead Temperature (Soldering, 10 sec.)	300°C

## Electrical Characteristics (Note 3)

Parameter	Conditions	LM747A/LM747E			LM747			LM747C			Units
		Min	Typ	Max	Min	Typ	Max	Min	Typ	Max	
Input Offset Voltage	$T_A = 25^\circ\text{C}$ $R_S \leq 10\text{ k}\Omega$ $R_S \leq 50\Omega$		0.8	3.0	1.0	5.0		2.0	6.0		mV
	$R_S \leq 50\Omega$ $R_S \leq 10\text{ k}\Omega$			4.0		6.0			7.5		mV
Average Input Offset Voltage Drift				15							$\mu\text{V}/^\circ\text{C}$
Input Offset Voltage Adjustment Range	$T_A = 25^\circ\text{C}$ , $V_S = \pm 20\text{V}$	±10			±15			±15			mV
Input Offset Current	$T_A = 25^\circ\text{C}$	3.0 30			20 200			20 200			nA
		70			85 500			300			
Average Input Offset Current Drift		0.5									nA/ $^\circ\text{C}$
Input Bias Current	$T_A = 25^\circ\text{C}$ $T_{\text{AMIN}} \leq T_A \leq T_{\text{AMAX}}$	30 80			80 500			80 500			nA
		0.210			1.5			0.8			$\mu\text{A}$
Input Resistance	$T_A = 25^\circ\text{C}$ , $V_S = \pm 20\text{V}$	1.0	6.0		0.3	2.0		0.3	2.0		M $\Omega$
	$V_S = \pm 20\text{V}$	0.5									
Input Voltage Range	$T_A = 25^\circ\text{C}$							±12 ±13			V
		±12 ±13			±12 ±13						
Large Signal Voltage Gain	$T_A = 25^\circ\text{C}$ , $R_L \geq 2\text{ k}\Omega$ $V_S = \pm 20\text{V}$ , $V_O = \pm 15\text{V}$	50									V/mV
	$V_S = \pm 15\text{V}$ , $V_O = \pm 10\text{V}$ $R_L \geq 2\text{ k}\Omega$				50	200		20	200		V/mV
	$V_S = \pm 20\text{V}$ , $V_O = \pm 15\text{V}$	32									V/mV
	$V_S = \pm 15\text{V}$ , $V_O = \pm 10\text{V}$				25			15			V/mV
	$V_S = \pm 5\text{V}$ , $V_O = \pm 2\text{V}$	10									V/mV
Output Voltage Swing	$V_S = \pm 20\text{V}$ $R_L \geq 10\text{ k}\Omega$ $R_L \geq 2\text{ k}\Omega$	±16 ±15									V
	$V_S = \pm 15\text{V}$ $R_L \geq 10\text{ k}\Omega$ $R_L \geq 2\text{ k}\Omega$				±12 ±10	±14 ±13		±12 ±10	±14 ±13		V
Output Short Circuit Current	$T_A = 25^\circ\text{C}$	10 10	25 40	35 40	25			25			mA
Common-Mode Rejection Ratio	$R_S \leq 10\text{ k}\Omega$ , $V_{\text{CM}} = \pm 12\text{V}$				70	90		70	90		dB
	$R_S \leq 50\text{ k}\Omega$ , $V_{\text{CM}} = \pm 12\text{V}$	80	95								

## Electrical Characteristics (Note 3) (Continued)

Parameter	Conditions	LM747A/LM747E			LM747			LM747C			Units
		Min	Typ	Max	Min	Typ	Max	Min	Typ	Max	
Supply Voltage Rejection Ratio	$V_S = \pm 20V$ to $V_S = \pm 5V$ $R_S \leq 50\Omega$ $R_S \leq 10\text{ k}\Omega$	86	96		77	96		77	96		dB
Transient Response Rise Time Overshoot	$T_A = 25^\circ\text{C}$ , Unity Gain		0.25 6.0	0.8 20		0.3 5			0.3 5		$\mu\text{s}$ %
Bandwidth (Note 4)	$T_A = 25^\circ\text{C}$	0.437	1.5								MHz
Slew Rate	$T_A = 25^\circ\text{C}$ , Unity Gain	0.3	0.7		0.5			0.5			$\text{V}/\mu\text{s}$
Supply Current/Amp	$T_A = 25^\circ\text{C}$			2.5	1.7	2.8		1.7	2.8		mA
Power Consumption/Amp	$T_A = 25^\circ\text{C}$ $V_S = \pm 20V$ $V_S = \pm 15V$		80	150		50	85		50	85	mW
LM747A	$V_S = \pm 20V$ $T_A = T_{A\text{MIN}}$ $T_A = T_{A\text{MAX}}$			165 135							mW
LM747E	$V_S = \pm 20V$ $T_A = T_{A\text{MIN}}$ $T_A = T_{A\text{MAX}}$			150 150 150							mW
LM747	$V_S = \pm 15V$ $T_A = T_{A\text{MIN}}$ $T_A = T_{A\text{MAX}}$				60	100		45	75		mW

**Note 1:** The maximum junction temperature of the LM747C/LM747E is  $100^\circ\text{C}$ . For operating at elevated temperatures, devices in the TO-5 package must be derated based on a thermal resistance of  $150^\circ\text{C}/\text{W}$ , junction to ambient, or  $45^\circ\text{C}/\text{W}$ , junction to case. The thermal resistance of the dual-in-line package is  $100^\circ\text{C}/\text{W}$ , junction to ambient.

**Note 2:** For supply voltages less than  $\pm 15V$ , the absolute maximum input voltage is equal to the supply voltage.

**Note 3:** These specifications apply for  $\pm 5V \leq V_S \leq \pm 20V$  and  $-55^\circ\text{C} \leq T_A \leq 125^\circ\text{C}$  for the LM747A and  $0^\circ\text{C} \leq T_A \leq 70^\circ\text{C}$  for the LM747E unless otherwise specified. The LM747 and LM747C are specified for  $V_S = \pm 15V$  and  $-55^\circ\text{C} \leq T_A \leq 125^\circ\text{C}$  and  $0^\circ\text{C} \leq T_A \leq 70^\circ\text{C}$ , respectively, unless otherwise specified.

**Note 4:** Calculated value from:  $0.35/\text{Rise Time}$  ( $\mu\text{s}$ ).

## Schematic Diagram (Each Amplifier)

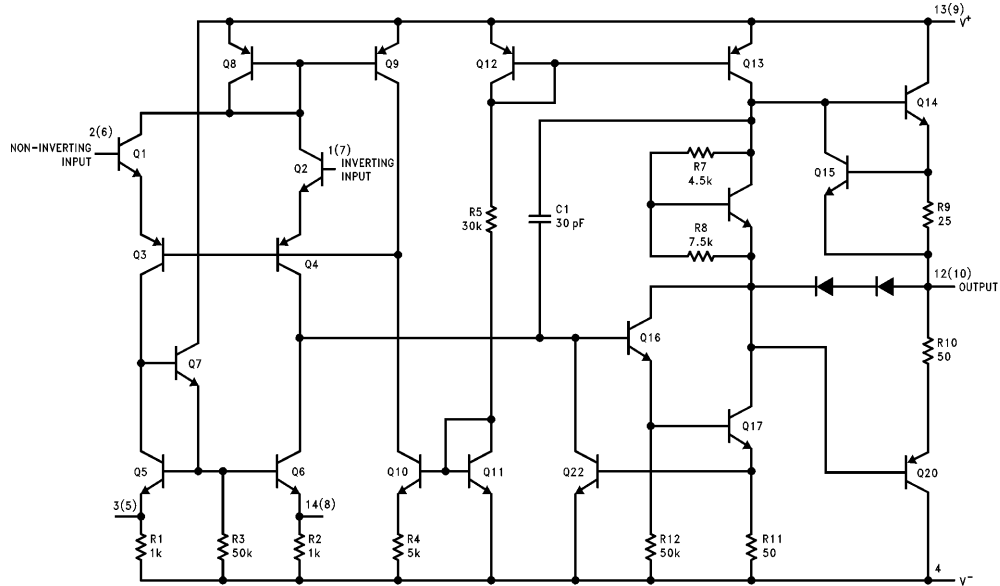

**Note:** Numbers in parentheses are pin numbers for amplifier B. DIP only.

# Typical Performance Characteristics

**Input Bias and Offset Currents vs Ambient Temperature**

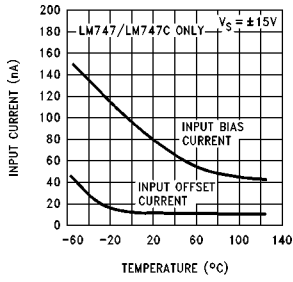

**DC Parameters vs Supply Voltage**

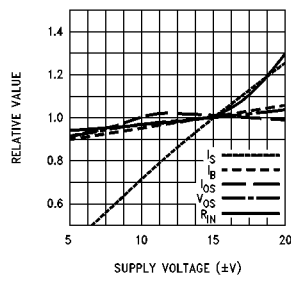

**Common Mode Rejection Ratio vs Frequency**

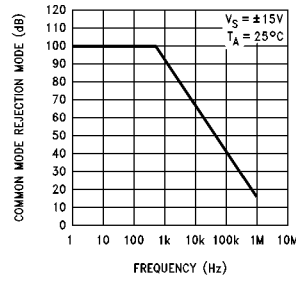

**Output Voltage Swing vs Frequency**

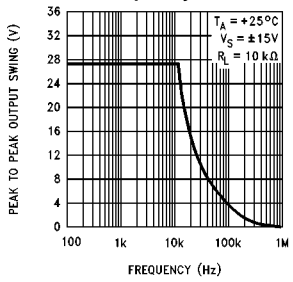

**Output Voltage Swing vs Load Resistance**

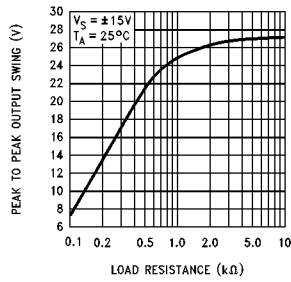

**Output Swing and Input Range vs Supply Voltage**

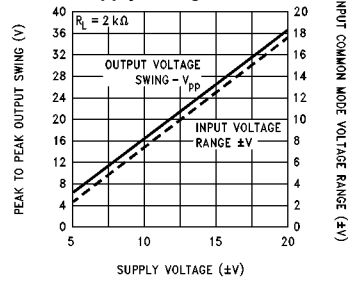

**Normalized DC Parameters vs Ambient Temperature**

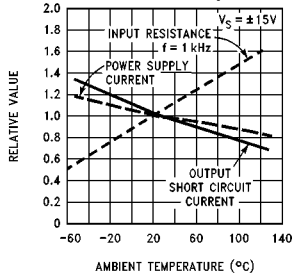

**Transient Response**

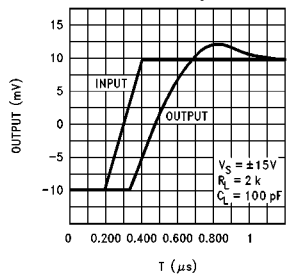

**Frequency Characteristics vs Ambient Temperature**

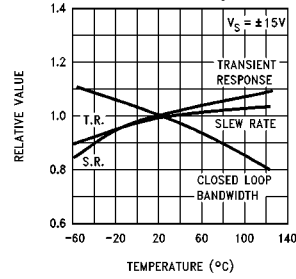

**Frequency Characteristics vs Supply Voltage**

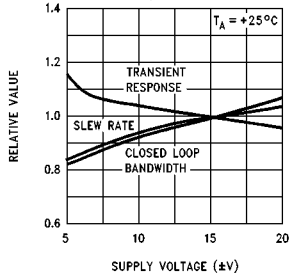

**Output Resistance vs Frequency**

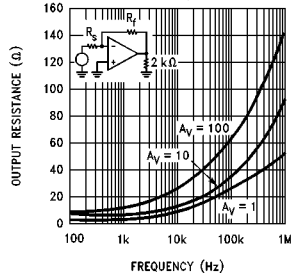

**Open Loop Transfer Characteristics vs Frequency**

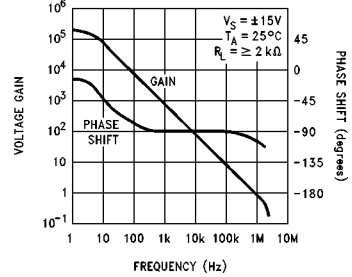

TL/H/11479-2

## Typical Performance Characteristics (Continued)

**Input Resistance and Input Capacitance vs Frequency**

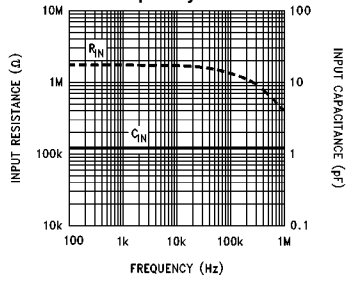

**Broadband Noise for Various Bandwidths**

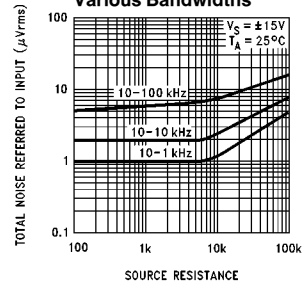

**Input Noise Voltage and Current vs Frequency**

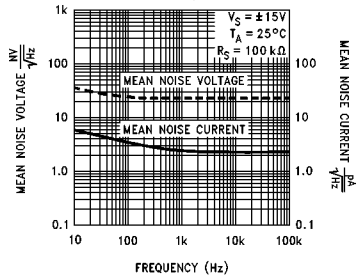

**Voltage Follower Large Signal Pulse Response**

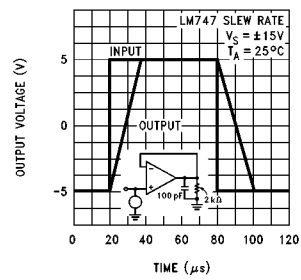

TL/H/11479-3



**Physical Dimensions** inches (millimeters)

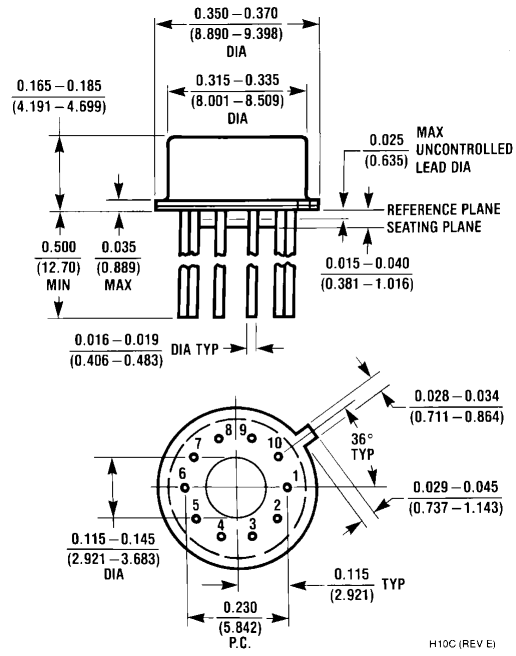

H10C (REV E)

**Metal Can Package (H)**  
**Order Number LM747H**  
**NS Package Number H10C**

Physical Dimensions inches (millimeters) (Continued)

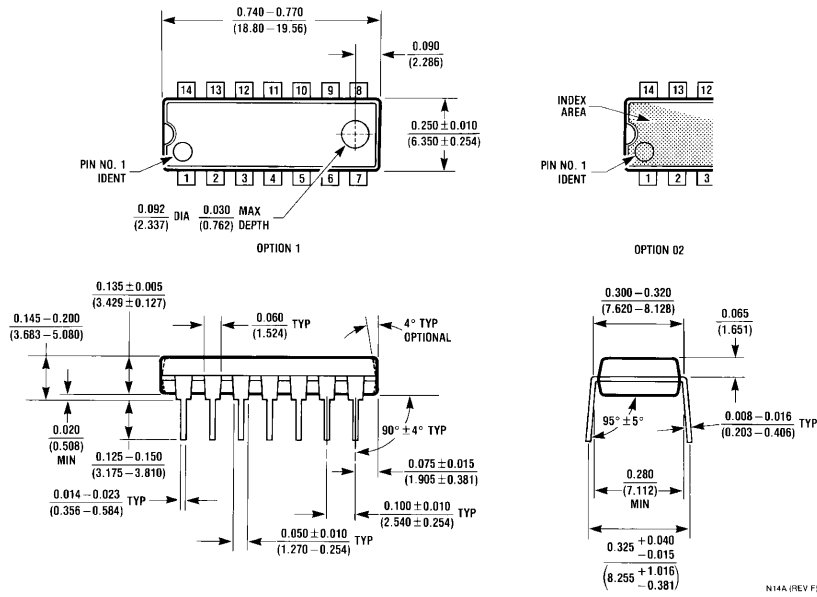

Dual-In-Line Package (N)  
 Order Number LM747CN or LM747EN  
 NS Package Number N14A

N14A (REV F)