

# DC-to-DC Converter Control Circuits

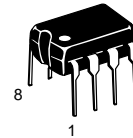
The MC34063A Series is a monolithic control circuit containing the primary functions required for DC-to-DC converters. These devices consist of an internal temperature compensated reference, comparator, controlled duty cycle oscillator with an active current limit circuit, driver and high current output switch. This series was specifically designed to be incorporated in Step-Down and Step-Up and Voltage-Inverting applications with a minimum number of external components. Refer to Application Notes AN920A/D and AN954/D for additional design information.

- Operation from 3.0 V to 40 V Input
- Low Standby Current
- Current Limiting
- Output Switch Current to 1.5 A
- Output Voltage Adjustable
- Frequency Operation to 100 kHz
- Precision 2% Reference

## MC34063A MC33063A

### DC-to-DC CONVERTER CONTROL CIRCUITS

#### SEMICONDUCTOR TECHNICAL DATA

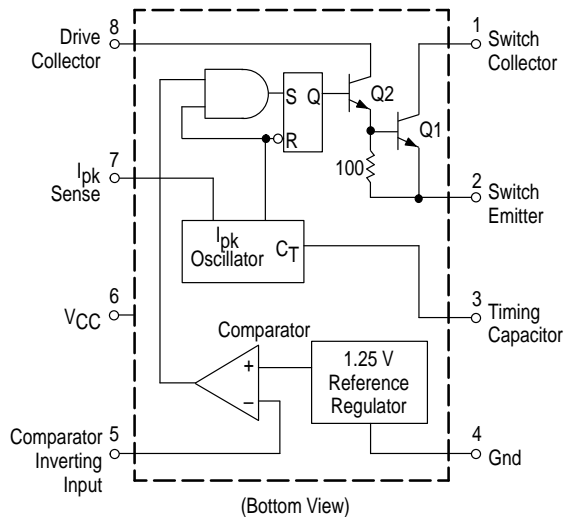


**P, P1 SUFFIX**  
PLASTIC PACKAGE  
CASE 626



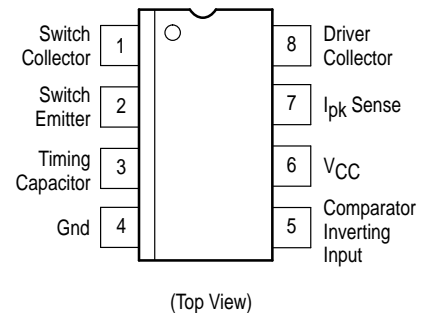
**D SUFFIX**  
PLASTIC PACKAGE  
CASE 751  
(SO-8)

#### Representative Schematic Diagram



This device contains 51 active transistors.

#### PIN CONNECTIONS



#### ORDERING INFORMATION

Device	Operating Temperature Range	Package
MC33063AD	$T_A = -40^\circ \text{ to } +85^\circ \text{C}$	SO-8
MC33063AP1		Plastic DIP
MC33063AVD	$T_A = -40^\circ \text{ to } +125^\circ \text{C}$	SO-8
MC33063AVP		Plastic DIP
MC34063AD	$T_A = 0^\circ \text{ to } +70^\circ \text{C}$	SO-8
MC34063AP1		Plastic DIP

# MC34063A MC33063A

## MAXIMUM RATINGS

Rating	Symbol	Value	Unit
Power Supply Voltage	$V_{CC}$	40	Vdc
Comparator Input Voltage Range	$V_{IR}$	-0.3 to +40	Vdc
Switch Collector Voltage	$V_{C(switch)}$	40	Vdc
Switch Emitter Voltage ( $V_{P_{in} 1} = 40$ V)	$V_{E(switch)}$	40	Vdc
Switch Collector to Emitter Voltage	$V_{CE(switch)}$	40	Vdc
Driver Collector Voltage	$V_{C(driver)}$	40	Vdc
Driver Collector Current (Note 1)	$I_{C(driver)}$	100	mA
Switch Current	$I_{SW}$	1.5	A
Power Dissipation and Thermal Characteristics Plastic Package, P, P1 Suffix $T_A = 25^\circ\text{C}$ Thermal Resistance	$P_D$ $R_{\theta JA}$	1.25 100	W $^\circ\text{C/W}$
SOIC Package, D Suffix $T_A = 25^\circ\text{C}$ Thermal Resistance	$P_D$ $R_{\theta JA}$	625 160	W $^\circ\text{C/W}$
Operating Junction Temperature	$T_J$	+150	$^\circ\text{C}$
Operating Ambient Temperature Range MC34063A MC33063AV MC33063A	$T_A$	0 to +70 -40 to +125 -40 to +85	$^\circ\text{C}$
Storage Temperature Range	$T_{stg}$	-65 to +150	$^\circ\text{C}$

**NOTES:** 1. Maximum package power dissipation limits must be observed.  
2. ESD data available upon request.

## ELECTRICAL CHARACTERISTICS ( $V_{CC} = 5.0$ V, $T_A = T_{low}$ to $T_{high}$ [Note 3], unless otherwise specified.)

Characteristics	Symbol	Min	Typ	Max	Unit
<b>OSCILLATOR</b>					
Frequency ( $V_{P_{in} 5} = 0$ V, $C_T = 1.0$ nF, $T_A = 25^\circ\text{C}$ )	$f_{osc}$	24	33	42	kHz
Charge Current ( $V_{CC} = 5.0$ V to 40 V, $T_A = 25^\circ\text{C}$ )	$I_{chg}$	24	35	42	$\mu\text{A}$
Discharge Current ( $V_{CC} = 5.0$ V to 40 V, $T_A = 25^\circ\text{C}$ )	$I_{dischg}$	140	220	260	$\mu\text{A}$
Discharge to Charge Current Ratio (Pin 7 to $V_{CC}$ , $T_A = 25^\circ\text{C}$ )	$I_{dischg}/I_{chg}$	5.2	6.5	7.5	-
Current Limit Sense Voltage ( $I_{chg} = I_{dischg}$ , $T_A = 25^\circ\text{C}$ )	$V_{ipk(sense)}$	250	300	350	mV
<b>OUTPUT SWITCH (Note 4)</b>					
Saturation Voltage, Darlington Connection (Note 5) ( $I_{SW} = 1.0$ A, Pins 1, 8 connected)	$V_{CE(sat)}$	-	1.0	1.3	V
Saturation Voltage, Darlington Connection ( $I_{SW} = 1.0$ A, $R_{P_{in} 8} = 82$ $\Omega$ to $V_{CC}$ , Forced $\beta = 20$ )	$V_{CE(sat)}$	-	0.45	0.7	V
DC Current Gain ( $I_{SW} = 1.0$ A, $V_{CE} = 5.0$ V, $T_A = 25^\circ\text{C}$ )	$h_{FE}$	50	75	-	-
Collector Off-State Current ( $V_{CE} = 40$ V)	$I_{C(off)}$	-	0.01	100	$\mu\text{A}$

**NOTES:** 3.  $T_{low} = 0^\circ\text{C}$  for MC34063A,  $-40^\circ\text{C}$  for MC33063A, AV  $T_{high} = +70^\circ\text{C}$  for MC34063A,  $+85^\circ\text{C}$  for MC33063A,  $+125^\circ\text{C}$  for MC33063AV  
4. Low duty cycle pulse techniques are used during test to maintain junction temperature as close to ambient temperature as possible.  
5. If the output switch is driven into hard saturation (non-Darlington configuration) at low switch currents ( $\leq 300$  mA) and high driver currents ( $\geq 30$  mA), it may take up to 2.0  $\mu\text{s}$  for it to come out of saturation. This condition will shorten the off time at frequencies  $\geq 30$  kHz, and is magnified at high temperatures. This condition does not occur with a Darlington configuration, since the output switch cannot saturate. If a non-Darlington configuration is used, the following output drive condition is recommended:

$$\text{Forced } \beta \text{ of output switch : } \frac{I_{C \text{ output}}}{I_{C \text{ driver}} - 7.0 \text{ mA}^*} \geq 10$$

\*The 100  $\Omega$  resistor in the emitter of the driver device requires about 7.0 mA before the output switch conducts.

# MC34063A MC33063A

**ELECTRICAL CHARACTERISTICS (continued)** ( $V_{CC} = 5.0\text{ V}$ ,  $T_A = T_{low}$  to  $T_{high}$  [Note 3], unless otherwise specified.)

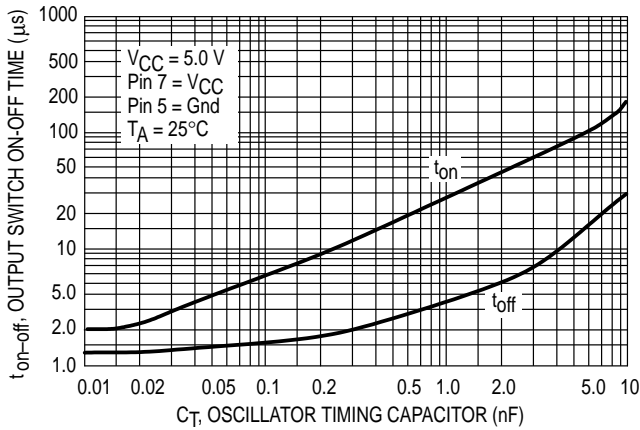
Characteristics	Symbol	Min	Typ	Max	Unit
<b>COMPARATOR</b>					
Threshold Voltage $T_A = 25^\circ\text{C}$ $T_A = T_{low}$ to $T_{high}$	$V_{th}$	1.225 1.21	1.25 –	1.275 1.29	V
Threshold Voltage Line Regulation ( $V_{CC} = 3.0\text{ V}$ to $40\text{ V}$ ) MC33063A, MC34063A MC33363AV	Regline	– –	1.4 1.4	5.0 6.0	mV
Input Bias Current ( $V_{in} = 0\text{ V}$ )	$I_B$	–	–20	–400	nA
<b>TOTAL DEVICE</b>					
Supply Current ( $V_{CC} = 5.0\text{ V}$ to $40\text{ V}$ , $C_T = 1.0\text{ nF}$ , Pin 7 = $V_{CC}$ , $V_{pin 5} > V_{th}$ , Pin 2 = Gnd, remaining pins open)	$I_{CC}$	–	–	4.0	mA

- NOTES:** 3.  $T_{low} = 0^\circ\text{C}$  for MC34063A,  $-40^\circ\text{C}$  for MC33063A, AV  $T_{high} = +70^\circ\text{C}$  for MC34063A,  $+85^\circ\text{C}$  for MC33063A,  $+125^\circ\text{C}$  for MC33063AV  
 4. Low duty cycle pulse techniques are used during test to maintain junction temperature as close to ambient temperature as possible.  
 5. If the output switch is driven into hard saturation (non-Darlington configuration) at low switch currents ( $\leq 300\text{ mA}$ ) and high driver currents ( $\geq 30\text{ mA}$ ), it may take up to  $2.0\text{ }\mu\text{s}$  for it to come out of saturation. This condition will shorten the off time at frequencies  $\geq 30\text{ kHz}$ , and is magnified at high temperatures. This condition does not occur with a Darlington configuration, since the output switch cannot saturate. If a non-Darlington configuration is used, the following output drive condition is recommended:

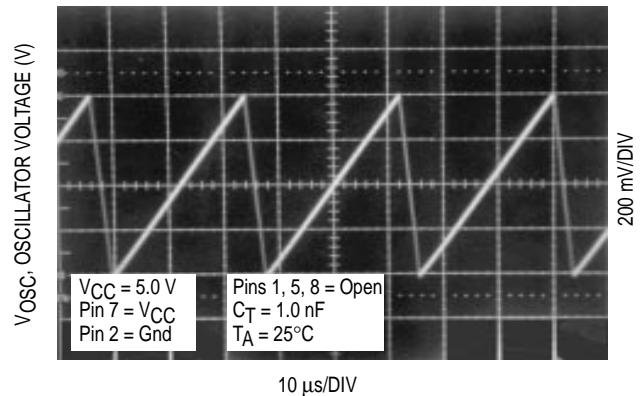
$$\text{Forced } \beta \text{ of output switch : } \frac{I_{C \text{ output}}}{I_{C \text{ driver}} - 7.0\text{ mA}^*} \geq 10$$

\*The  $100\text{ }\Omega$  resistor in the emitter of the driver device requires about  $7.0\text{ mA}$  before the output switch conducts.

**Figure 1. Output Switch On–Off Time versus Oscillator Timing Capacitor**

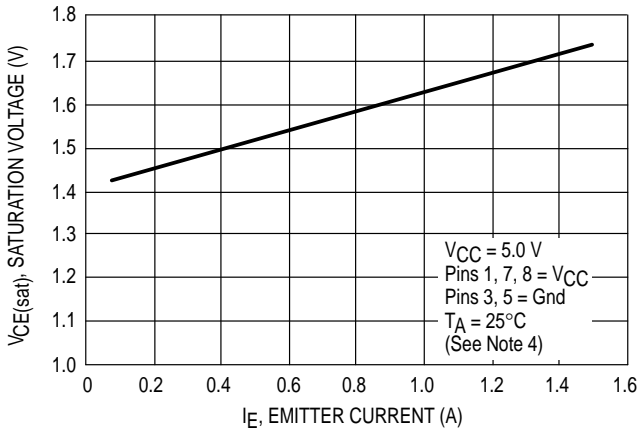


**Figure 2. Timing Capacitor Waveform**

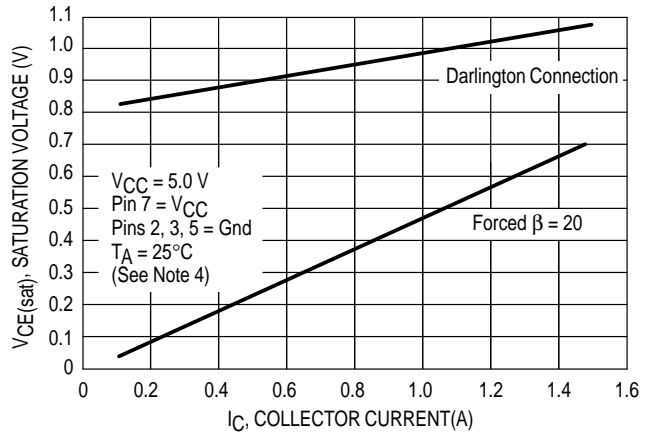


# MC34063A MC33063A

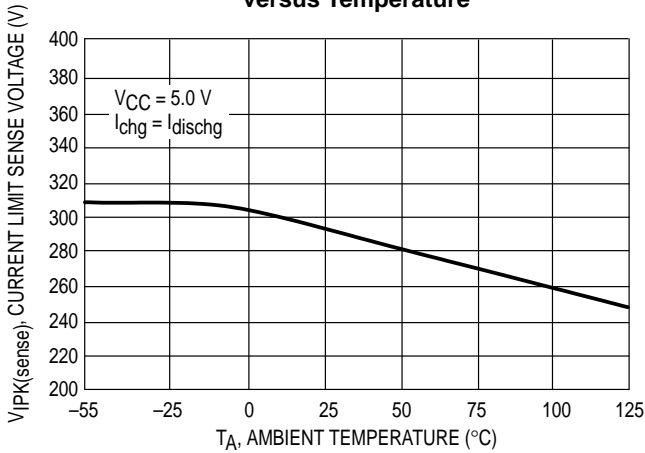
**Figure 3. Emitter Follower Configuration Output Saturation Voltage versus Emitter Current**



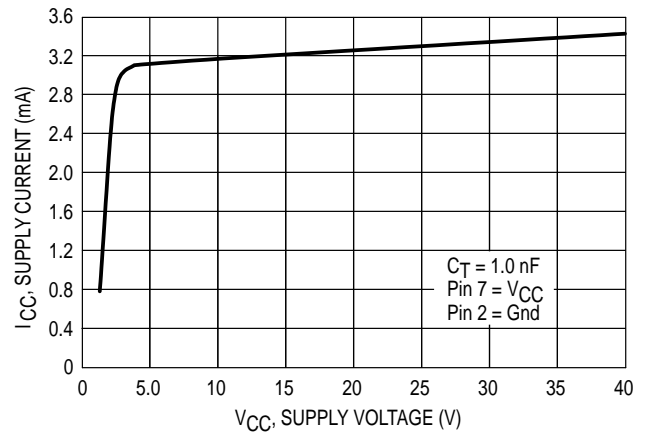
**Figure 4. Common Emitter Configuration Output Switch Saturation Voltage versus Collector Current**



**Figure 5. Current Limit Sense Voltage versus Temperature**



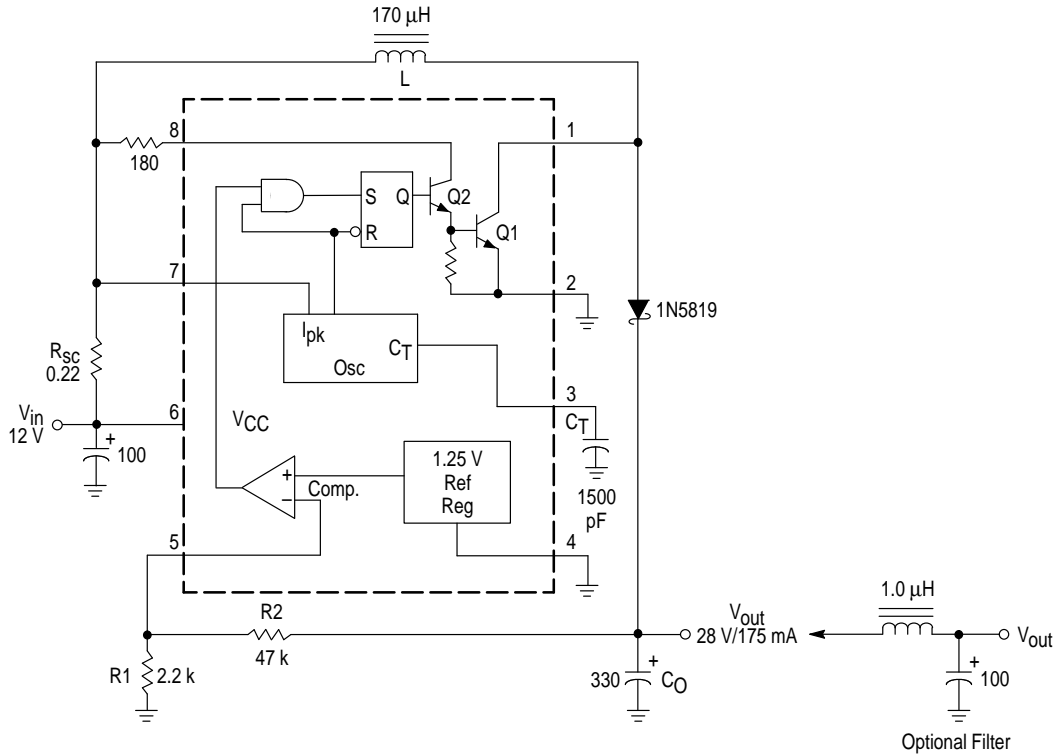
**Figure 6. Standby Supply Current versus Supply Voltage**



**NOTE:** 4. Low duty cycle pulse techniques are used during test to maintain junction temperature as close to ambient temperature as possible.

# MC34063A MC33063A

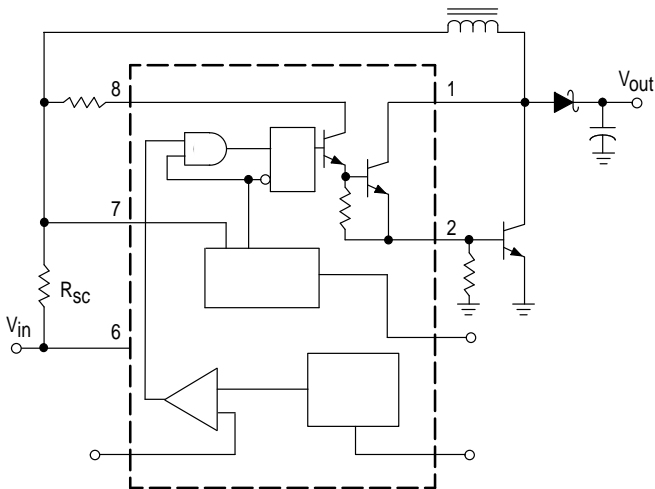
Figure 7. Step-Up Converter



Test	Conditions	Results
Line Regulation	$V_{in} = 8.0 \text{ V to } 16 \text{ V}, I_O = 175 \text{ mA}$	$30 \text{ mV} = \pm 0.05\%$
Load Regulation	$V_{in} = 12 \text{ V}, I_O = 75 \text{ mA to } 175 \text{ mA}$	$10 \text{ mV} = \pm 0.017\%$
Output Ripple	$V_{in} = 12 \text{ V}, I_O = 175 \text{ mA}$	$400 \text{ mVpp}$
Efficiency	$V_{in} = 12 \text{ V}, I_O = 175 \text{ mA}$	$87.7\%$
Output Ripple With Optional Filter	$V_{in} = 12 \text{ V}, I_O = 175 \text{ mA}$	$40 \text{ mVpp}$

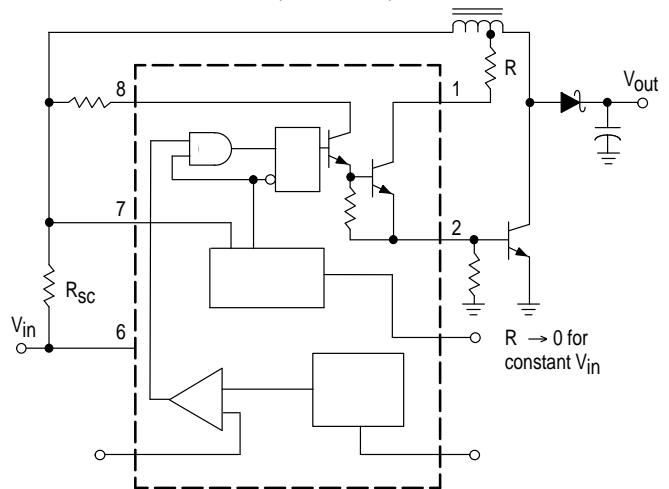
Figure 8. External Current Boost Connections for  $I_C$  Peak Greater than 1.5 A

8a. External NPN Switch



8b. External NPN Saturated Switch

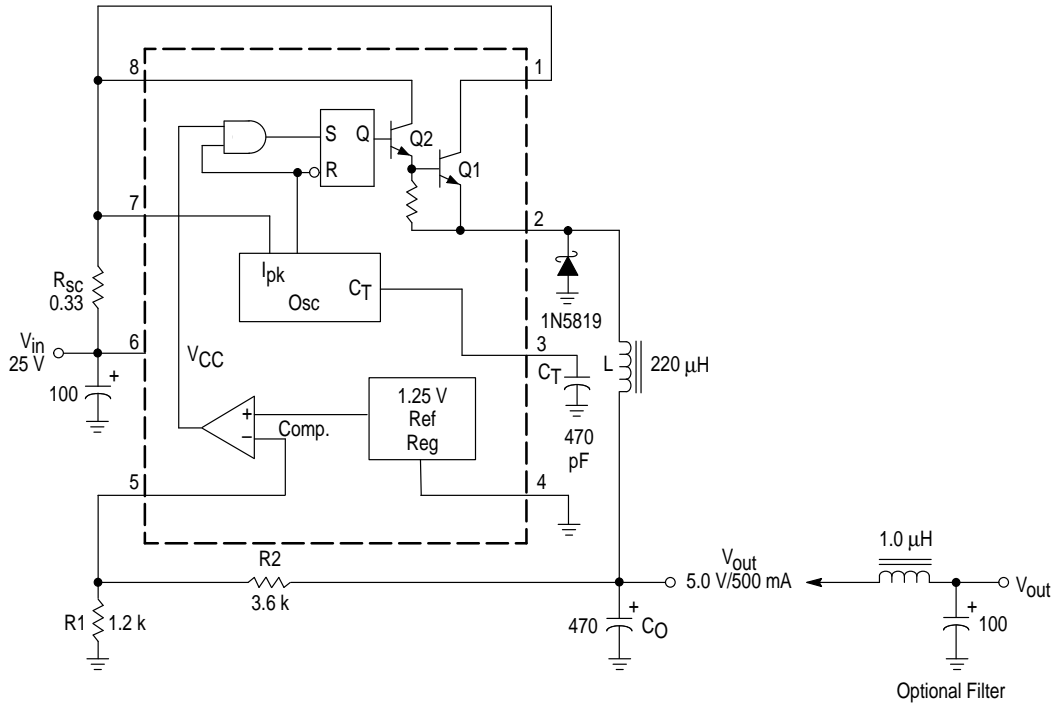
(See Note 5)



**NOTE:** 5. If the output switch is driven into hard saturation (non-Darlington configuration) at low switch currents ( $\leq 300 \text{ mA}$ ) and high driver currents ( $\geq 30 \text{ mA}$ ), it may take up to  $2.0 \mu\text{s}$  to come out of saturation. This condition will shorten the off time at frequencies  $\geq 30 \text{ kHz}$ , and is magnified at high temperatures. This condition does not occur with a Darlington configuration, since the output switch cannot saturate. If a non-Darlington configuration is used, the following output drive condition is recommended.

# MC34063A MC33063A

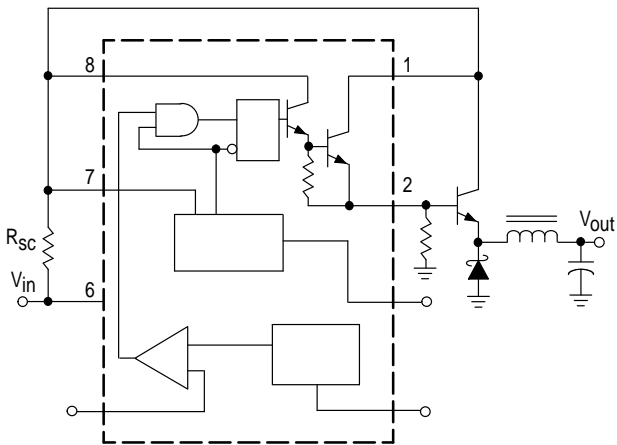
Figure 9. Step-Down Converter



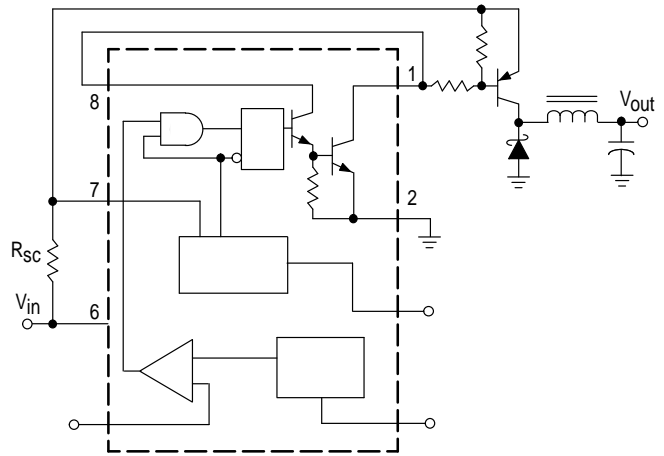
Test	Conditions	Results
Line Regulation	$V_{in} = 15\text{ V to }25\text{ V}, I_O = 500\text{ mA}$	$12\text{ mV} = \pm 0.12\%$
Load Regulation	$V_{in} = 25\text{ V}, I_O = 50\text{ mA to }500\text{ mA}$	$3.0\text{ mV} = \pm 0.03\%$
Output Ripple	$V_{in} = 25\text{ V}, I_O = 500\text{ mA}$	$120\text{ mVpp}$
Short Circuit Current	$V_{in} = 25\text{ V}, R_L = 0.1\ \Omega$	$1.1\text{ A}$
Efficiency	$V_{in} = 25\text{ V}, I_O = 500\text{ mA}$	$83.7\%$
Output Ripple With Optional Filter	$V_{in} = 25\text{ V}, I_O = 500\text{ mA}$	$40\text{ mVpp}$

Figure 10. External Current Boost Connections for  $I_C$  Peak Greater than 1.5 A

10a. External NPN Switch

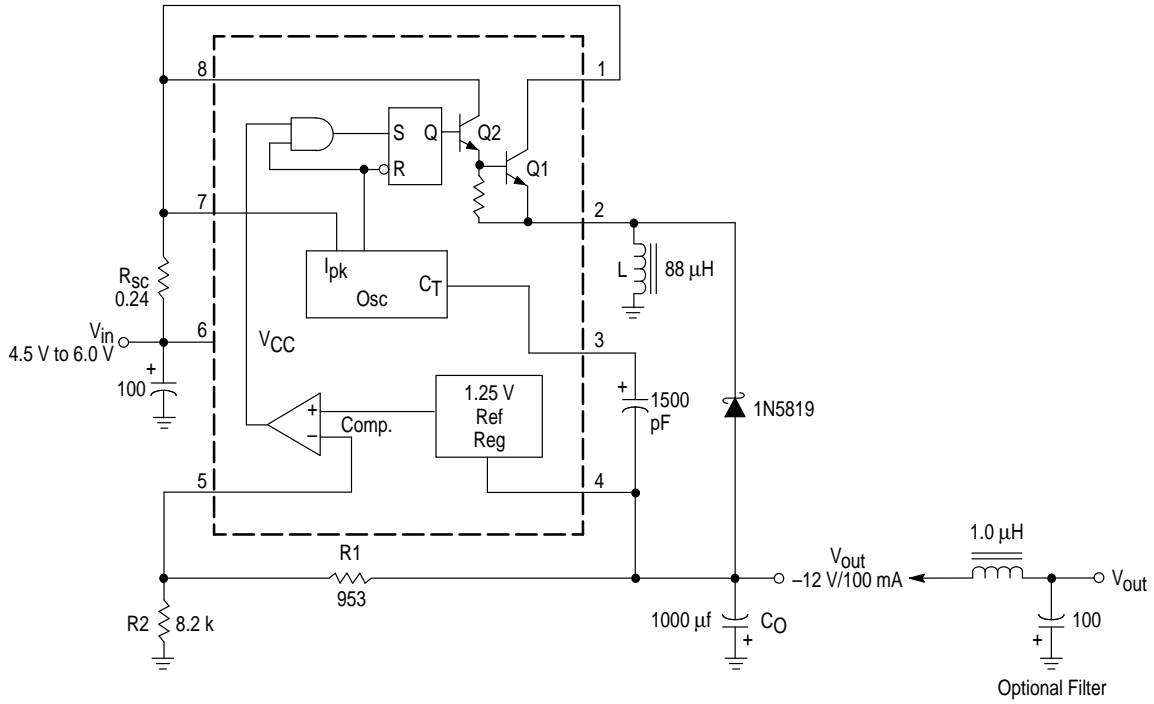


10b. External PNP Saturated Switch



# MC34063A MC33063A

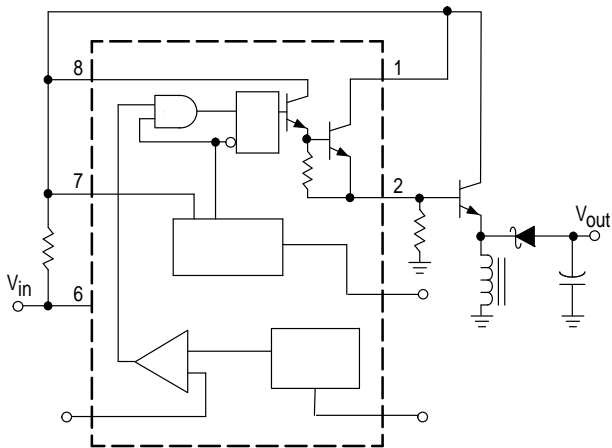
Figure 11. Voltage Inverting Converter



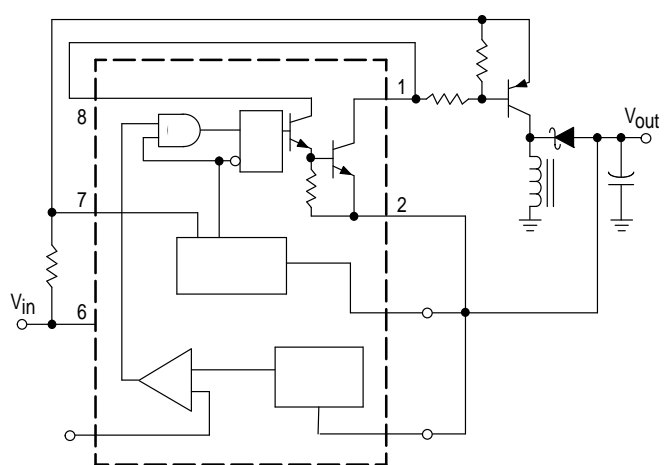
Test	Conditions	Results
Line Regulation	$V_{in} = 4.5 \text{ V to } 6.0 \text{ V}$ , $I_O = 100 \text{ mA}$	$3.0 \text{ mV} = \pm 0.012\%$
Load Regulation	$V_{in} = 5.0 \text{ V}$ , $I_O = 10 \text{ mA to } 100 \text{ mA}$	$0.022 \text{ V} = \pm 0.09\%$
Output Ripple	$V_{in} = 5.0 \text{ V}$ , $I_O = 100 \text{ mA}$	$500 \text{ mVpp}$
Short Circuit Current	$V_{in} = 5.0 \text{ V}$ , $R_L = 0.1 \Omega$	$910 \text{ mA}$
Efficiency	$V_{in} = 5.0 \text{ V}$ , $I_O = 100 \text{ mA}$	$62.2\%$
Output Ripple With Optional Filter	$V_{in} = 5.0 \text{ V}$ , $I_O = 100 \text{ mA}$	$70 \text{ mVpp}$

Figure 12. External Current Boost Connections for  $I_C$  Peak Greater than 1.5 A

12a. External NPN Switch

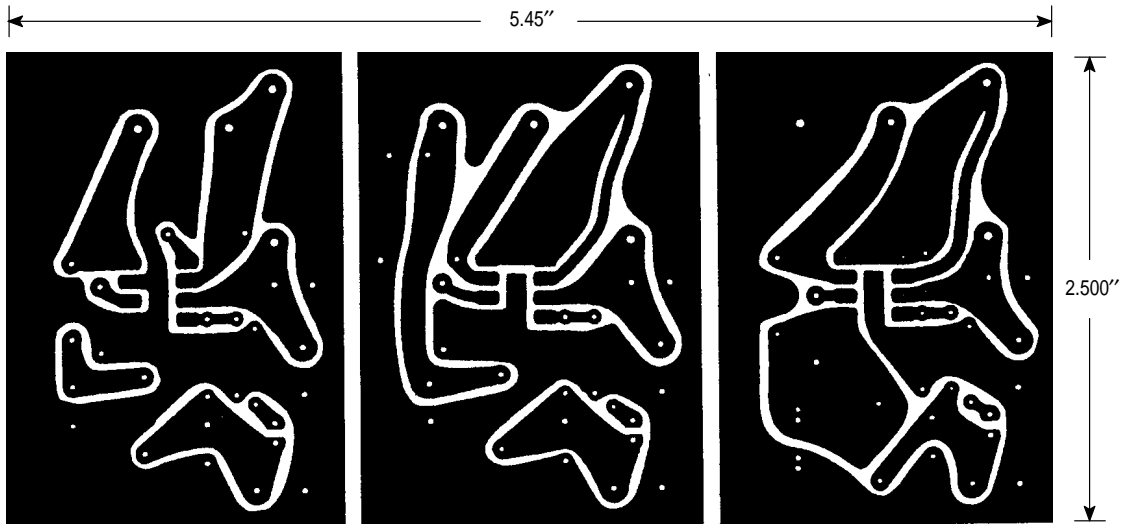


12b. External PNP Saturated Switch

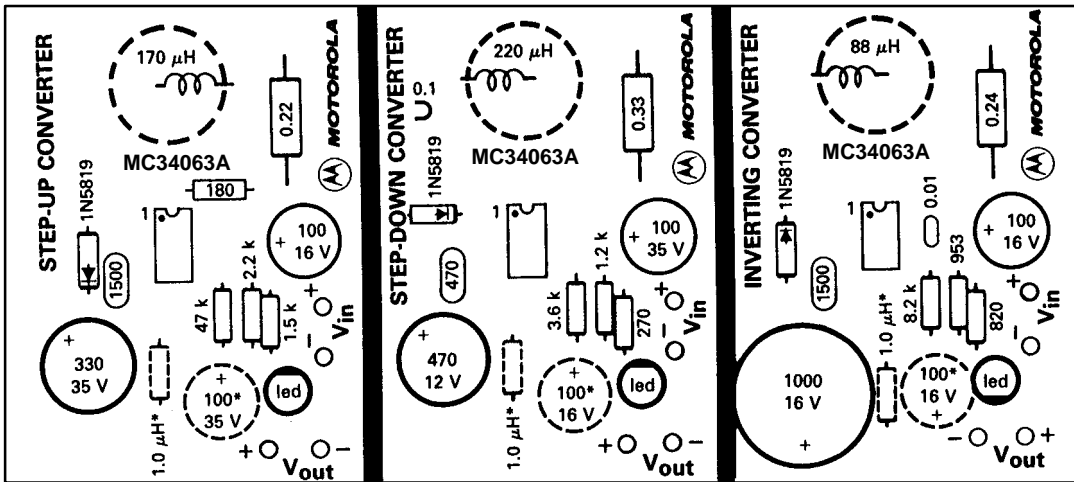


# MC34063A MC33063A

Figure 13. Printed Circuit Board and Component Layout  
(Circuits of Figures 7, 9, 11)



(Top view, copper foil as seen through the board from the component side)



(Top View, Component Side)

\*Optional Filter.

## INDUCTOR DATA

Converter	Inductance ( $\mu\text{H}$ )	Turns/Wire
Step-Up	170	38 Turns of #22 AWG
Step-Down	220	48 Turns of #22 AWG
Voltage-Inverting	88	28 Turns of #22 AWG

All inductors are wound on Magnetics Inc. 55117 toroidal core.

# MC34063A MC33063A

Figure 14. Design Formula Table

Calculation	Step-Up	Step-Down	Voltage-Inverting
$t_{on}/t_{off}$	$\frac{V_{out} + V_F - V_{in(min)}}{V_{in(min)} - V_{sat}}$	$\frac{V_{out} + V_F}{V_{in(min)} - V_{sat} - V_{out}}$	$\frac{ V_{out}  + V_F}{V_{in} - V_{sat}}$
$(t_{on} + t_{off})$	$\frac{1}{f}$	$\frac{1}{f}$	$\frac{1}{f}$
$t_{off}$	$\frac{t_{on} + t_{off}}{\frac{t_{on}}{t_{off}} + 1}$	$\frac{t_{on} + t_{off}}{\frac{t_{on}}{t_{off}} + 1}$	$\frac{t_{on} + t_{off}}{\frac{t_{on}}{t_{off}} + 1}$
$t_{on}$	$(t_{on} + t_{off}) - t_{off}$	$(t_{on} + t_{off}) - t_{off}$	$(t_{on} + t_{off}) - t_{off}$
$C_T$	$4.0 \times 10^{-5} t_{on}$	$4.0 \times 10^{-5} t_{on}$	$4.0 \times 10^{-5} t_{on}$
$I_{pk}(switch)$	$2I_{out(max)} \left( \frac{t_{on}}{t_{off}} + 1 \right)$	$2I_{out(max)}$	$2I_{out(max)} \left( \frac{t_{on}}{t_{off}} + 1 \right)$
$R_{sc}$	$0.3/I_{pk}(switch)$	$0.3/I_{pk}(switch)$	$0.3/I_{pk}(switch)$
$L_{(min)}$	$\left( \frac{V_{in(min)} - V_{sat}}{I_{pk}(switch)} \right) t_{on(max)}$	$\left( \frac{V_{in(min)} - V_{sat} - V_{out}}{I_{pk}(switch)} \right) t_{on(max)}$	$\left( \frac{V_{in(min)} - V_{sat}}{I_{pk}(switch)} \right) t_{on(max)}$
$C_O$	$9 \frac{I_{out} t_{on}}{V_{ripple(pp)}}$	$\frac{I_{pk}(switch)(t_{on} + t_{off})}{8V_{ripple(pp)}}$	$9 \frac{I_{out} t_{on}}{V_{ripple(pp)}}$

$V_{sat}$  = Saturation voltage of the output switch.  
 $V_F$  = Forward voltage drop of the output rectifier.

**The following power supply characteristics must be chosen:**

$V_{in}$  – Nominal input voltage.

$V_{out}$  – Desired output voltage,  $|V_{out}| = 1.25 \left( 1 + \frac{R2}{R1} \right)$

$I_{out}$  – Desired output current.

$f_{min}$  – Minimum desired output switching frequency at the selected values of  $V_{in}$  and  $I_O$ .

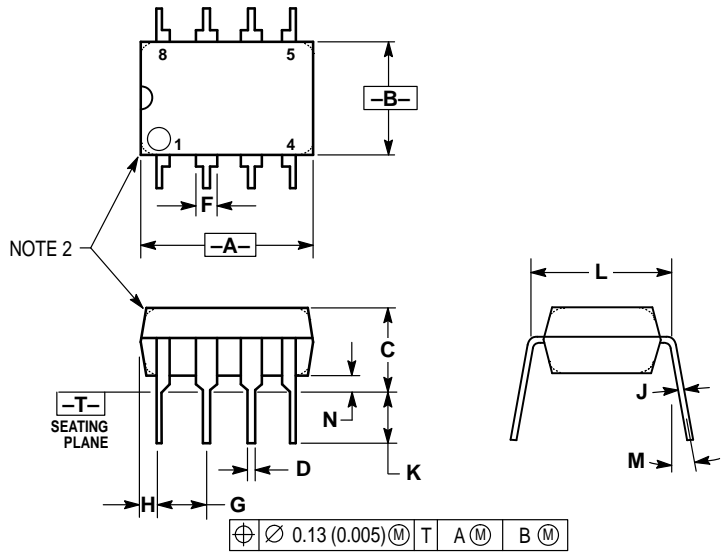
$V_{ripple(pp)}$  – Desired peak-to-peak output ripple voltage. In practice, the calculated capacitor value will need to be increased due to its equivalent series resistance and board layout. The ripple voltage should be kept to a low value since it will directly affect the line and load regulation.

**NOTE:** For further information refer to Application Note AN920A/D and AN954/D.

# MC34063A MC33063A

## OUTLINE DIMENSIONS

**P, P1 SUFFIX**  
**PLASTIC PACKAGE**  
**CASE 626-05**  
**ISSUE K**

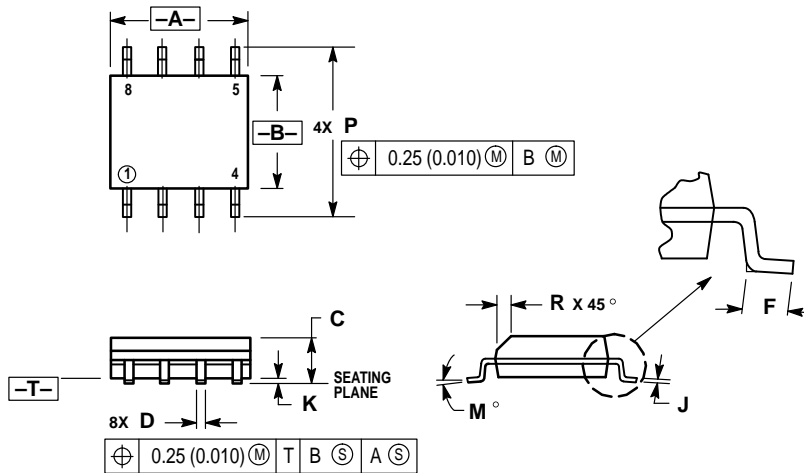


**NOTES:**

1. DIMENSION L TO CENTER OF LEAD WHEN FORMED PARALLEL.
2. PACKAGE CONTOUR OPTIONAL (ROUND OR SQUARE CORNERS).
3. DIMENSIONING AND TOLERANCING PER ANSI Y14.5M, 1982.

DIM	MILLIMETERS		INCHES	
	MIN	MAX	MIN	MAX
A	9.40	10.16	0.370	0.400
B	6.10	6.60	0.240	0.260
C	3.94	4.45	0.155	0.175
D	0.38	0.51	0.015	0.020
F	1.02	1.78	0.040	0.070
G	2.54 BSC		0.100 BSC	
H	0.76	1.27	0.030	0.050
J	0.20	0.30	0.008	0.012
K	2.92	3.43	0.115	0.135
L	7.62 BSC		0.300 BSC	
M	— 10°		— 10°	
N	0.76	1.01	0.030	0.040

**D SUFFIX**  
**PLASTIC PACKAGE**  
**CASE 751-05**  
**(SO-8)**  
**ISSUE P**



**NOTES:**

1. DIMENSIONING AND TOLERANCING PER ANSI Y14.5M, 1982.
2. CONTROLLING DIMENSION: MILLIMETER.
3. DIMENSIONS A AND B DO NOT INCLUDE MOLD PROTRUSION.
4. MAXIMUM MOLD PROTRUSION 0.15 (0.006) PER SIDE.
5. DIMENSION D DOES NOT INCLUDE DAMBAR PROTRUSION. ALLOWABLE DAMBAR PROTRUSION SHALL BE 0.127 (0.005) TOTAL IN EXCESS OF THE D DIMENSION AT MAXIMUM MATERIAL CONDITION.

DIM	MILLIMETERS		INCHES	
	MIN	MAX	MIN	MAX
A	4.80	5.00	0.189	0.196
B	3.80	4.00	0.150	0.157
C	1.35	1.75	0.054	0.068
D	0.35	0.49	0.014	0.019
F	0.40	1.25	0.016	0.049
G	1.27 BSC		0.050 BSC	
J	0.18	0.25	0.007	0.009
K	0.10	0.25	0.004	0.009
M	0° 7°		0° 7°	
P	5.80	6.20	0.229	0.244
R	0.25	0.50	0.010	0.019